

[www.riftvalleyuniversity.org](http://www.riftvalleyuniversity.org)



# RIFT VALLEY UNIVERSITY

## FIRST AID MANUAL

2024  
SEPTEMBER,  
ADDIS ABABA,  
ETHIOPIA





**RIFT VALLEY  
UNIVERSITY**



# FIRST AID MANUAL

# Contents

Contents	4
1. Introduction	5
1.1. Background of rift valley university	5
1.2. Mission, Vision values of Rift valley university	6
1.3. Objective of the manual	7
1.4. General principles of first aid	9
1.4.1. Six principles of first aid	9
1.4.2. Four main steps	16
2. Emergencies	
2.1. Unconsciousness	28
2.2. Stroke	38
2.3. Choking	41
2.4. Chest discomfort	45
2.5. Severe bleeding and shock	47
2.6. Poisoning	53
2.7. Emergency child birth	57
3. Injuries	
3.1. Skin wounds	67
3.2. Burns	73
3.3. Stings and bites	78
3.4. Injuries to muscles, joints or limbs	87
3.5. Injuries to head, neck or back	93
3.6. Eye injuries	97
3.7. Nose bleed	103
4. Illnesses	
4.1. Fainting	107
4.2. Fever	110
4.3. Fits	116
4.4. Diarrhoea	119
4.5. Rash	126
5. Content of first aid kit	129
5.1. Small first aid box	129
5.2. Large first aid box	131

# 1. Introduction

## 1.1. Background of Rift Valley University

Rift Valley University initially conceived as College, was established in Adama City of East Shawa Zone, Oromia National Regional State in October 2000 G.C, foreseeing the core values of *good governance, commitment to quality services and community development, gender sensitivity, secularism and non-partisan, creativity, responsiveness, team work spirit, and work culture* parallel to the nation's development goals along with the purpose of producing competent, ethical and skilled manpower without making any distinction between people of different ethnic, religious, social, economic and political backgrounds.

After securing its legal personality, the then Rift Valley College strongly worked on the accreditation processes of its training and education programs from all regulatory bodies, and managed to get full accreditation from Higher Education Relevance and Quality Agency and Regional States TVET Agencies. Taking its flourishing capacity and quality service into account, the Ministry of Education, in collaboration with HERQA, granted the rank of University College in August 2007 G.C. This was not an easy task and a simple success story for the institution. The two regulatory bodies had conducted rigorous evaluation of the systems of the institution, physical facilities and learning resources of its campuses and faculties to come to decision of such status change. Afterwards, Rift Valley University College rigorously worked towards becoming a full-fledged university and realized itself as Rift Valley University in August 2014

G.C.

Currently, Rift Valley University being a pioneer and the largest Private Higher Learning Institution in Ethiopia has been delivering quality education to the citizens and foreigners who have lived in the country for different purposes. Furthermore, the University has 50 Campuses, 3

TVET Colleges and College of Open and Distance Education (32 accredited branches) with diversified fields of study across the country. Over the last two decades, thousands have joined and graduated with Technical and Vocational Education and Training (TVET), Bachelor's degree, and Master's degree that enabled them to support themselves and their families. Others have also managed to create their own jobs whereby they exhibited the merits of their training and education at Rift Valley University in fostering the already established development goals of the country.

## **1.2. Mission, Vision and Values of Rift Valley University**

### **1.2.1. Mission**

Rift Valley University exists to produce graduates who are competent, committed and ethical citizens; to engage in innovative and problem solving research; and to deliver sustainable community services.

### **1.2.2. Vision**

RVU aspires to be one of the leading universities in teaching, research and community engagement in Africa by 2030.

### **1.2.3. Values of RVU**

The following are the values cherished by RVU:

1. Quality and Excellence
2. Responsiveness to customer needs
3. Good Governance
4. Professionalism and Academic Freedom
5. Team Spirit
6. Professional Integrity and Ethical Practices
7. Creativity and Innovativeness
8. Commitment to Community Services
9. Recognition of Diversity and Gender Sensitivity
10. Social Responsibility

## **1.3. Objectives of the Manual**

### **1.3.1. General Objective**

The main objective of this manual is to give a guidance on up-to-date basic first aid techniques and be utilized by Rift valley university workers and stakeholders to increase the chances of improving the condition of, or saving the life of an injured or ill person, by giving the right kind of assistance both at work place or at home.

### **1.1.2. Specific Objectives**

The specific objectives of this manual are to:-

- To preserve life, which involves essential practices to ensure the victim's safety.
- To Prevent Deterioration
- To Promote Recovery
- To Relieve Pain
- To Protect The Unconscious



## **1.4. General principles of first aid**

### **1.4.1. Six principles of first aid**

When administering first aid, you have to take these 6 principles into consideration.

**1. Keep calm during an emergency situation.**

Try to bring your emotions under control before you act. Only proceed when you have regained your calm.

**2. Avoid infection.**

If possible, wash your hands with water and soap before and after administering first aid. Hand-washing techniques can be found on page 10. Other tips on how to avoid infection can be found on page 11.

**3. Act as a first aider.**

Make sure you do not make the situation worse.

**4. Ensure the comfort of the ill or injured person.**

Protect the ill or injured person against cold and heat, but do not give food or drinks.

**5. Give psychosocial first aid.**

Try to make the ill or injured person feel better. Listen to him, talk quietly, explain what you are doing and touch him gently. More information can be found on page 12.

**6. Emotional reactions afterwards might occur.**

Talk to family, friends, fellow first aiders or a religious leader. If you are still worried, talk to a professional and seek counselling.



## Technique: Hand-washing

Wash your hands before and after giving first aid, after taking of disposable gloves and after using the toilet.

The entire procedure should take between 40 and 60 seconds in total.

1. Wet your hands under running water.

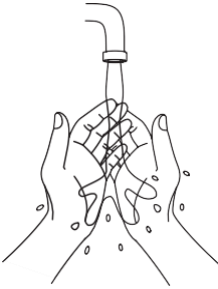

2. Use soap. If you have liquid soap, this is the best.

Alternatively, use ash that is no longer hot.



3. Rub your hands firmly together and wash thoroughly. Make sure the soap touches all parts of your hands: the tips of your fingers, thumbs and the skin between your fingers.



4. Rinse your hands well. Use plenty of water.

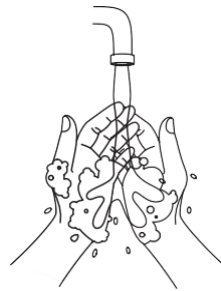

5. Dry your hands with a clean towel or cloths.

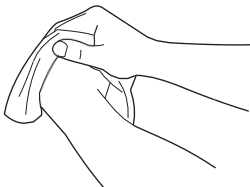

### 1.4.1.1. How to avoid infection

- **Avoid direct contact with blood or bodily fluids:**
  - Wear clean disposable gloves.
  - If gloves are not available, cover your hands with clean plastic bags.

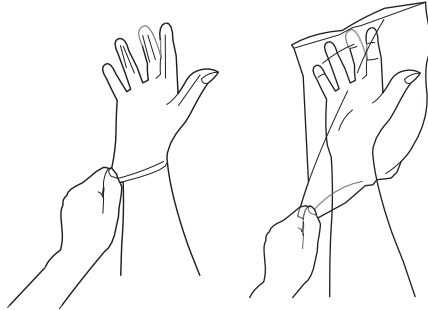

- Cover your own cuts or sores with waterproof plasters or with other dressings if you have larger wounds.



- Be careful with sharp objects, such as broken glass, sharp rocks or working equipment.
- If blood comes into contact with any wound on your skin or splashes into your eyes, nose or mouth, wash thoroughly with clean water and soap as soon as possible.
- After treating the ill or injured person, place bloody or soiled dressings into a plastic bag, then place your gloves in the bag as well and arrange for the bag to be burned or buried.
- Use clean drinking water or boiled and cooled water if a person needs to drink.
- If no gloves or plastic bags are available, you can also direct the ill or injured person what he can do himself.

- Do not touch the wound or any part of the dressing that will cover the wound without wearing gloves.

#### 1.4.1.2. Giving psychosocial first aid

Providing psychosocial support to an ill or injured person is part of offering first aid. But it's not always easy. Persons' reactions can vary enormously. Some are confused or deny that the situation is serious, others are incredibly angry, while others panic. These reactions help them to cope with the situation. Try if possible to see the situation from his point of view. This will help you to empathise with him and get a true picture of the situation.

A few simple guidelines will help you in this area:

- Approach the ill or injured person in a respectful, friendly way, without any preconceptions.
- Introduce yourself and tell him your name. Tell him that you have followed a first aid course.
- Ask his name.
- Listen to what he is telling you and show sympathy. This will enable you to win his trust.
- Ask what has happened.
- Ask permission to offer first aid (even if just to touch him).
- Position yourself at the same (eye) level as the ill or injured person.
- Give information to the ill or injured person:
  - Describe what has happened, for example "You have been hit by a motorbike" or "You have fainted".

- Explain what you are doing to help him, what you can and will do, and why you are doing

it. That way he feels involved. It will help him to calm down

and feel safe with you and the help you are offering.

- It may also help you to offer help in an organised way and not to forget anything.

- Keep explaining what you are doing, even if he does not appear to hear you or does not react (for example, if he is unconscious). He may hear more than you think. So always be careful what you say.
- Stay with him. Never leave him alone if possible.
- Explain what kind of help is on its way. Look after his possessions. If he has to go to hospital, make sure his possessions and clothing accompany him. If necessary, give them to the police.

- Offer assistance with a few practical matters, like calling a family member.
- Where possible give him the feeling that he is in control and let him do whatever he can (for example, support a painful arm himself). That way you show respect and give him a better understanding of what has happened.
- Do not make any statements you cannot substantiate. Only give him correct information. Tell him that you do not know, if he asks a question you cannot answer.

If the ill or injured person is a child, then talk to (one of) the parents if possible. If the parent accepts you as a first aider, the child is also more likely to trust you.

- Using simple words, explain what you are going to do and why. Answer any of the child's questions honestly. Their imaginings are often far worse than the reality.
- Speak normally to them.
- Don't be patronising. Make sure that the child feels involved. So, don't talk over his head. Don't take a child away from his parents or other trusted people unless necessary. Distract the child if possible.
- Never leave a child alone. Reunite them as soon as possible with a trusted person.

## 1.4.2. Four main steps

Although accidents can be extremely different, you should always follow these 4 main steps in first aid. They will help you to correctly assess the situation and administer first aid in an appropriate way.

**The 4 main steps are:**

1. **Make the area safe.**
2. **Evaluate the ill or injured person's condition.**
3. **Seek help.**
4. **Give first aid.**

### Step 1: Make the area safe

Never approach the scene of an accident if there is any danger to:

- You;
- Bystanders;
- The injured person.

First try to eliminate the danger if possible. It may be a simple measure such as turning off the ignition of the car, thereby reducing the risk of an explosion or fire. Put up a sign to warn approaching traffic.



As a general rule, the injured person should not be moved from the scene of the accident. Any movement may make the injury worse. Nevertheless, some situations require moving the injured person (see below). Techniques on how to move an ill or injured person can be found below.

### **When to move an injured person**

Only move an injured person if:

- The injured person is in more danger if he is left there;
- The situation cannot be made safe;
- Medical help will not arrive soon;
- You can do so without putting yourself in danger.

If you have to move the injured person, considering the following:

- Explain what you are going to do, when he is conscious. Ask him to follow your instructions;
- Do not twist the head, neck or body. If possible, support his neck. If he has an injured spine, movement may cause further damage;
- Move the injured person quickly, but try to keep his body as still as possible;
- Move the injured person to the nearest safe place.



## Technique: Moving an ill or injured person

There are different techniques possible for moving an ill or injured person. Which technique is most appropriate depends on the situation.

- **Are you alone?**

- Crouch down behind the ill or injured person. Hold his wrists and pull

OR

- Grasp his clothing under the arms and carefully pull backwards.

OR

- If the ill or injured person is able to hold onto you, consider



▪ **Is there another person to help you?**

▪ Use the two-handed lift:

- Squat on one side of the ill or injured person, facing the other first aider.
- Put one arm around his back for support (gripping his clothes).
- Put your other arm under his thighs, while grasping the other first aider's wrist.
- Lift him.

▪ Try the four-handed lift:

- Stand behind the ill or injured person, facing the other first aider.
- Grasp your own left wrist with your own right hand.
- Grasp the other first aider's right wrist with your free hand, thereby creating a 'seat'.
- Bend down and ask the ill or injured person to sit on this 'seat' and put his arms around your necks.
- Lift him.

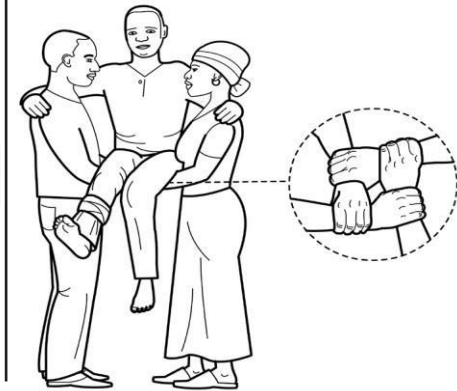
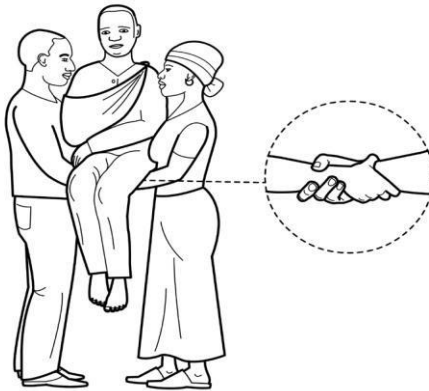

- **Are there 4 other people to help you?**

- Let the 4 first aiders kneel on one knee on each side of the ill or injured person.
- Each first aider places his hands carefully beneath the ill or injured person so as to support the back as much as possible.
- Position yourself at the head end and support the head and neck of the ill or injured person.
- On your command, all first aiders lift him as evenly as possible.

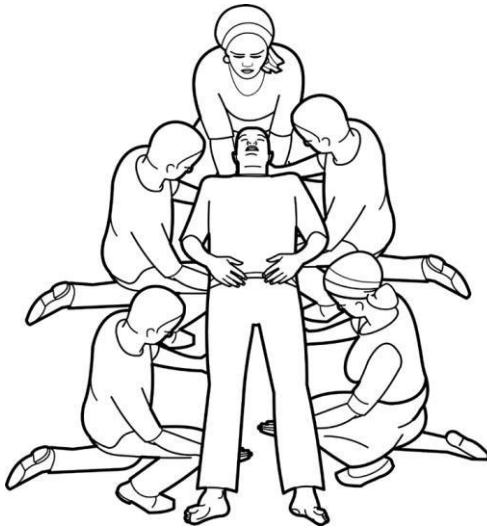

- Do you need a stretcher to move an ill or injured person? Improvise one, using a blanket or other cloths and two sticks.

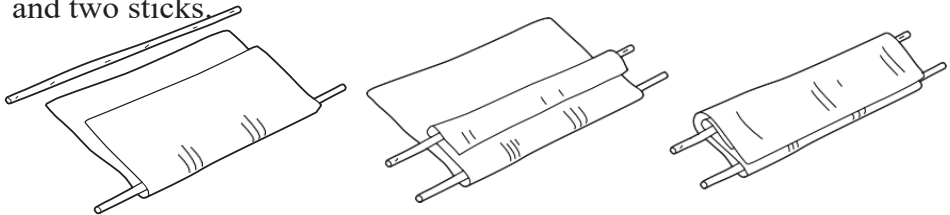

- **Do you need to get an ill or injured person into a car?**
  - Move the passenger seat backwards as far as possible and recline the seat backwards.
  - Slide the ill or injured person carefully into the car.
  - Use the recovery position for persons that are unconscious. (see 'Technique recovery position' page 30)
  - Stay with him until you reach medical help (see page 20).

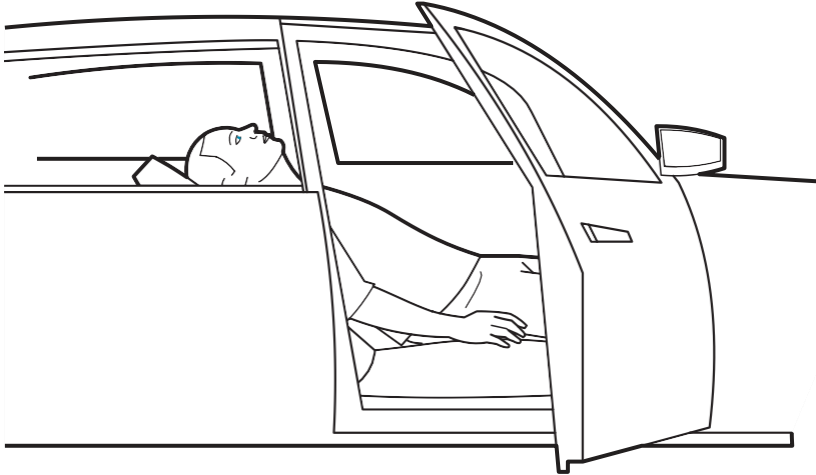

## Step 2: Evaluate the ill or injured person's condition

Once the area is safe, evaluate the condition of the ill or injured person. To do so:

1. **Check for consciousness.**
2. **Open the airway.**
3. **Check for breathing.**

### 1) CHECK FOR CONSCIOUSNESS

- Tap the ill or injured person on the shoulders.
- Loudly ask: "Are you okay?".

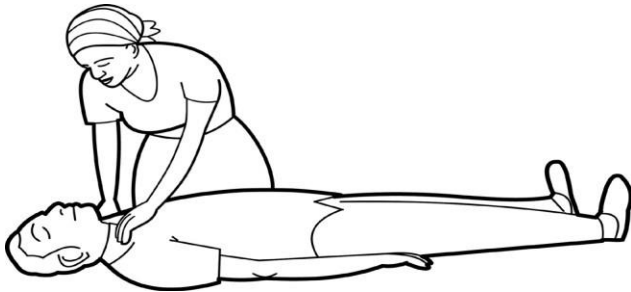

There are 2 options:

#### 1. He responds

- Leave him in the position in which you found him. Do not move him, unless he is in danger.
- Try to find out what is wrong with him.
- Find medical help if this is needed.
- Keep checking him to make sure that he is not getting worse.

#### 2. He does not respond

- Shout for help.
- Do not leave the person if you are alone. Ask a bystander to seek help or to arrange for bringing him to a medical care provider. Tell him to come back to you to confirm if help has been secured. The person urgently needs help.

## 2) OPEN THE AIRWAY

- Put one hand on the forehead of the ill or injured person. Gently press it down and tilt the head back.
- Put two finger tops of your other hand beneath the chin. Do not push into the soft part of the chin, because this can cause breathing difficulties.
- Lift the chin up to open the airway.

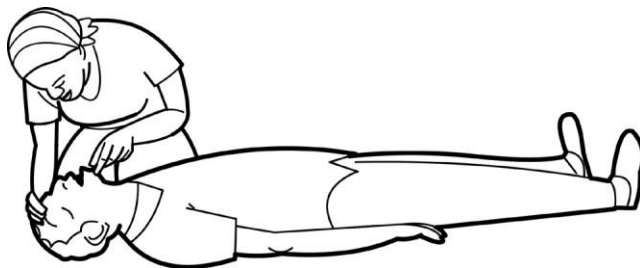

## 3) CHECK FOR BREATHING

Check the person's breathing for 10 seconds:

- **Look:** can you see his chest moving?
- **Listen:** can you hear him breathing?
- **Feel:** can you feel his breath on your cheek?

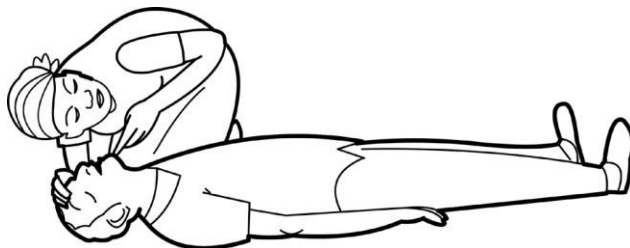
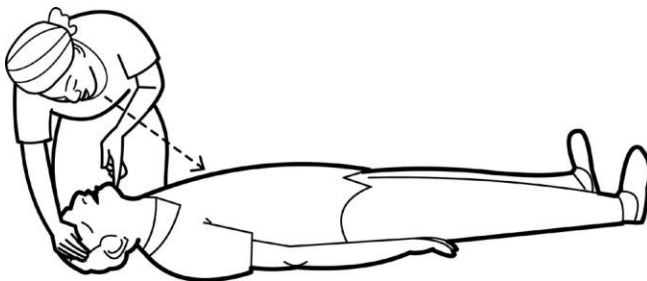

There are 2 options:

**1. He is breathing normally**

- Put the unconscious person in the recovery position (see 'Technique: recovery position' page 30).
- Only put him in this position when you do not suspect a spinal injury (see 'Injuries to head, neck or back' page 93).
- Do you suspect a spinal injury? Let him lay down, as long as he is breathing normally.

**2. He is not breathing normally**

- Immediately start cardiopulmonary resuscitation (CPR) (see 'Unconsciousness without normal breathing' page 32).

## **Gasping**

In the first few minutes after a heart arrest, it often appears as if the ill person is trying to breathe. There may be only small signs of breathing or there may be noisy gasps every now and then. Do not confuse these signs with normal breathing. If you are not sure if he is breathing normally, then act as though he has stopped breathing.

## Step 3: Seek help

Once you have checked the ill or injured person's condition, you can decide if urgent help is needed.

### How to seek help

Whenever the phrase 'Seek help' is mentioned in the following chapters, we refer to the following actions:

Ask a bystander to seek help or to arrange for bringing the ill or injured person to a medical care provider. Tell him to come back to you to confirm if help has been secured. The ill or injured person urgently needs help. Shout or call for help if you are alone, but do not leave the ill or injured person.

### Which type of help should you seek?

- Ambulance
  - An ambulance is the best way to transport ill or injured persons.
  - Call an ambulance if it can be obtained in a short time.
  - Other types of transport can be made into ambulances as well:
    - A motorcycle;
    - A bicycle;
    - A car (see page 21).

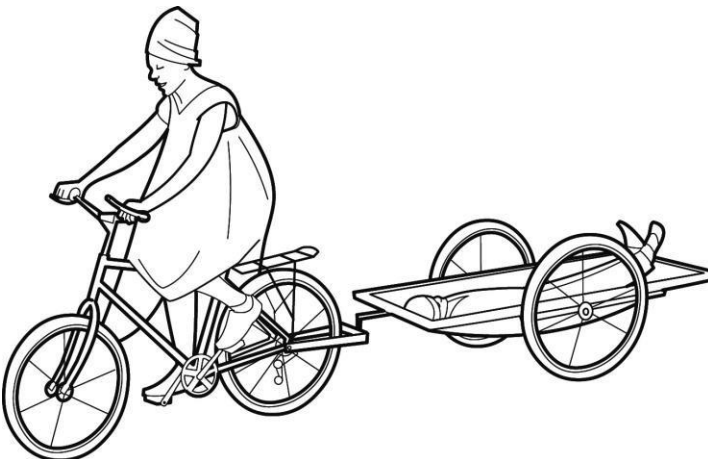

- Police
  - Seek police help in case of road accidents.

#### Step 4: Give first aid

Provide first aid in the priority of the most life-threatening case first.



# 2 Emergencies

## 2.1 Unconsciousness



A person has lost consciousness if he does not react to your actions by opening his eyes or answering your questions. Loss of consciousness causes the muscles to relax, including those of the tongue. As a result, the tongue can block the airway.

Unconsciousness may be caused by for instance a head injury, heart arrest, stroke or poisoning.

## 2.1.1 Unconsciousness with normal breathing



### What do you see?

- The ill or injured person appears to be asleep, but does not wake up even if you shake or shout at him;
- He is breathing normally.



### What should you do?

Ask yourself the following question: may the ill or injured person have a spinal injury (see 'Injuries to head, neck or back' page 87)?

There are 2 options:

#### 1. **No, I do not suspect a spinal injury**

- Put him into the recovery position (see 'Technique: recovery position' page 25).

#### 2. **Yes, he may have a spinal injury**

- Keep him lying on his back, tilt his head back and lift his chin up to keep the airway open.
- Check for consciousness and breathing each minute.
- Only put him into the recovery position if you have to leave him alone or if he is vomiting. If possible, support his neck while turning him into the recovery position.



## Technique: Recovery position

This position will keep the airway of the unconscious person open. It will also prevent vomit from entering the lungs.

1. Remove the person's spectacles if necessary.
2. Kneel down alongside him. Make sure that both legs are outstretched.
3. Place his arm nearest to you at a right angle to the body. Bend the forearm upwards with the palm facing up.

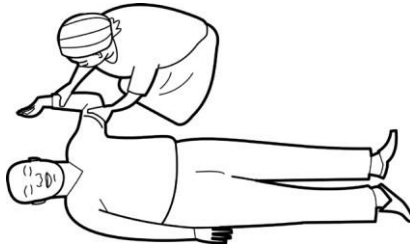

4. Lay the other arm across his chest. Hold the back of his hand against his cheek. Keep his hand in place.

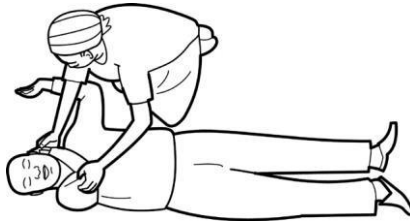

5. With your free hand, grasp the leg on the other side of his body at the knee. Raise and bend the leg, keeping the foot flat on the ground.

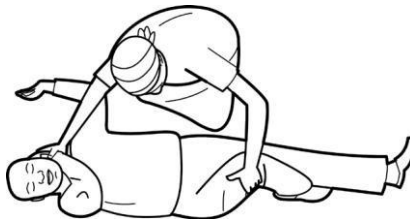

6. Pull the raised leg towards you. Keep holding the back of his hand against his cheek. Roll him towards you to bring him onto his side.



7. Position the upper leg in such a way that hip and knee are at right angles.



8. To keep the airway open, tilt the head back. Make sure that his mouth is angled to the ground. This will prevent him from choking on blood or vomit.



9. If necessary, adjust his hand under the cheek to keep the head tilted.

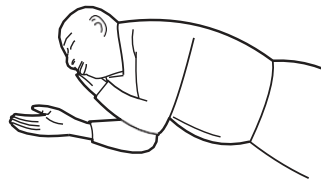

10. Keep checking his breathing.

- The same technique can be used to put an **infant or child** into the recovery position. If necessary, you can place a small pillow or rolled up blanket behind the infant's back. This will keep him more stable.
- When placing a **pregnant woman** that is injured into the recovery position, it is best to turn her onto her left side.

## 2.1.2 Unconsciousness without normal breathing



### What do you see?

- The ill person appears to be asleep, but does not wake up even if you shake or shout at him;
- The chest does not move up or down. You do not feel or hear air going in and out of his nose or mouth.



### What should you do?

- Seek help **See page 22**
- Place the person on a firm surface.
- Start cardiopulmonary resuscitation (CPR) as soon as possible:
  - Give 30 chest compressions without stopping (see
  - Give 2 rescue breaths (see
  - Continue CPR: repeat the cycle of 30 compressions and 2 rescue breaths until:
    - professional help arrives and takes over;
    - he starts to wake up and breathe normally;
    - someone takes over from you;
    - you are too tired to carry on.



### Was the person drowning?

- Remove him rapidly and safely from the water, but do not put yourself in danger! Try throwing a rope or something that floats to hold onto him if he's conscious.
- Do not try to remove water from the lungs.
- Start chest compressions and rescue breaths immediately.
- Cover him with a coat or a blanket to keep him warm.



## Are there several trained first aiders present?

Alternate with each other during resuscitation. Switch every 2 minutes, preferably after giving the rescue breaths. The switch should happen with minimal interruption.



## Technique: Chest compressions

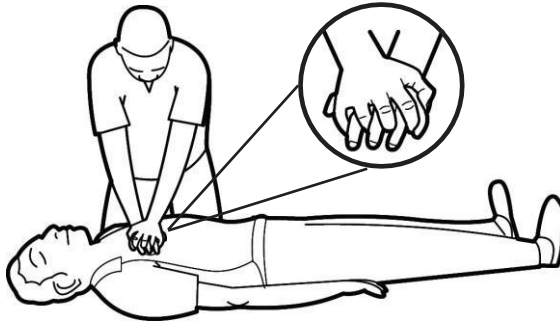

1. Place the heel of one hand in the centre of the ill person's chest.
2. Place the heel of the other hand on top of your first hand.
3. Lock your fingers together.
4. You should not apply pressure to his ribs, the upper part of the stomach or the bottom end of the breastbone.
5. Make sure your shoulders are directly above his chest.
6. With outstretched arms, push 5 cm (maximum 6 cm) directly downwards.
7. Allow the chest to fully rise again. Do not allow your hands to shift or to come away from the breastbone.
8. Give 30 chest compressions at a rate of 100 compressions per minute (not faster than 120 compressions per minute).



## Technique: Rescue breaths

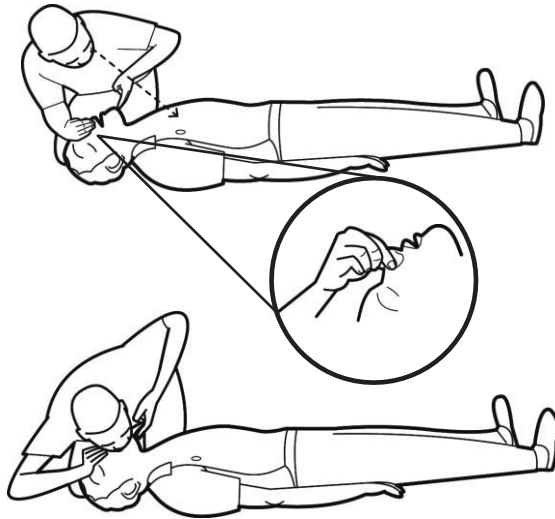

1. Open the airway of the ill person (see page 21).
2. Pinch his nose with the hand that is on the forehead.
3. Take a normal breath.
4. Cover his mouth completely with your mouth so that you seal it with your lips.
5. Calmly blow the air into his mouth for 1 second.
6. Watch to see if the chest rises.
  - If it does: give the second breath.
  - If it doesn't:
    - Check to see whether there is anything in his mouth.
    - Remove any visible items that are blocking or may block the airway.
    - Check that the head is well tilted and the chin is lifted properly.
    - Give the second breath.
- Make no more than 2 attempts at giving rescue breaths each time before switching to chest compressions.
- If you cannot or do not want to give rescue breaths, you can just continue to give chest compressions.



## Technique: Cardiopulmonary resuscitation in children older than 1 year

1. Give 5 initial rescue breaths.
2. Give 30 chest compressions:
  - Use one hand to give chest compressions. Keep the other one on the forehead of the child.
  - Compress at least one third of the depth of the chest (about 5 cm).
  - Give 30 compressions at the rate of 100 to 120 per minute.



3. Give 2 rescue breaths.
4. Continue CPR: repeat the cycle of 30 compressions and 2 rescue breaths.



## Technique: Cardiopulmonary resuscitation in babies under 1 year old

1. Give 5 initial rescue breaths.
  - Do not pinch the nose of the baby, but cover the mouth and nose of the baby with your own mouth.
2. Give 30 chest compressions:
  - Compress the chest with the two fingers (the middle and index fingers).
  - Compress at least one third of the depth of the chest (about 4 cm)

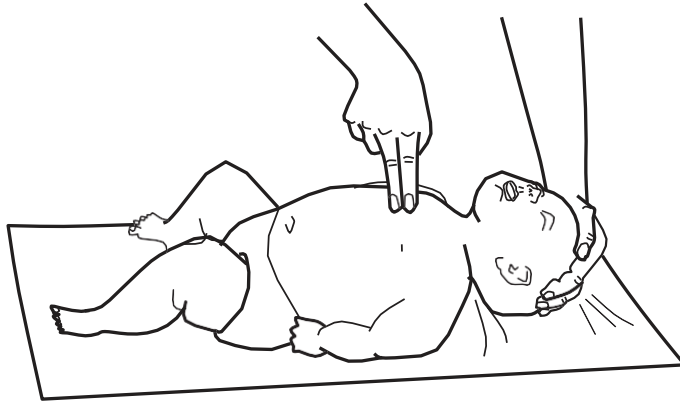

3. Give 2 rescue breaths
4. Continue CPR: repeat the cycle of 30 compressions and 2 rescue breaths.



## Prevention of drowning

- Be careful near a river, pond, lake, sea or swimming pool. Keep a close watch on children in the neighbourhood of water.

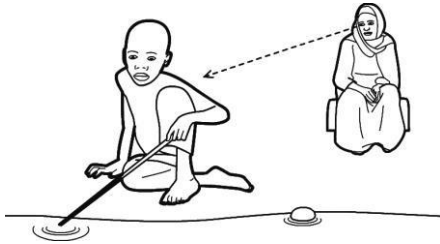

- Do not leave small children alone near water. They can also drown in small amounts of water, such as washing tubs, water wells, irrigation ditches or animal drinking troughs.



- Fill in unused ditches and water holes near your home.
- In case of used water reservoirs, you can make a fence around it. You can make one using branches, sticks, wood blocks or whatever is available.

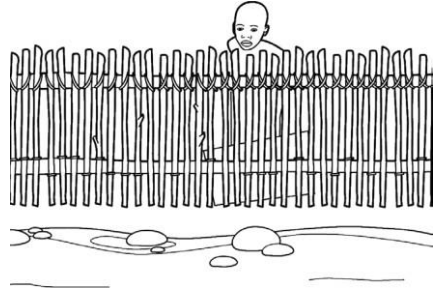

- If available, use a flotation device for children and anyone who cannot swim. However, keep paying attention, as an accident can still occur. Those able to swim should also use a flotation device when going into deep or fast-flowing water, even if they are on a boat.

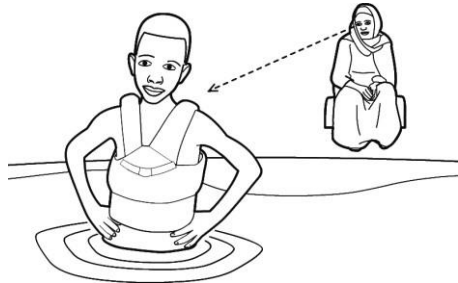

## 2.2 Stroke



A stroke or CVA (cerebrovascular accident) results from a blood clot or a weakness in an artery of the brain that leads to blockage or bleeding. As a consequence, oxygen supply to the brain is interrupted, leading to the death of surrounding brain tissue.



### What do you see?

The symptoms are dependent on the specific brain area and the size of the area that was affected. The ill person may:

- experience disturbances in consciousness, such as loss of consciousness, sleepiness, confusion, agitation, arousal;
- speak slowly or experience slurring of speech;
- experience dizziness or an insecure gait. He might appear drunk, which may be reinforced by nausea;
- show numbness, weakness or loss of mobility of an arm, hand, leg or facial muscles on one side of the body;
- complain of headache;
- suffer from loss of vision or hearing;
- experience drooping of one side of the mouth, often in combination with a difficulty to speak or swallow.



## What should you do?

- Check for signs of a stroke using the FAST test (see 'Technique: FAST test' page 40)
- Seek help (page 20).
- Place the ill person in a position he finds comfortable.
  - Stroke casualties often have difficulty breathing, so it is better to let him sit upright.
  - If he is unable to sit, place him in the recovery position.
- Do not encourage movement. Keep him calm.
- Arrange urgent transport to medical care yourself if you are alone.
- Keep checking for consciousness and breathing.
- Stay with him until medical help is available.



Do not give **food or drinks** to a person that is having a stroke. He is at risk of choking or vomiting.



## Technique: FAST test

You can check if the ill person has had a stroke via the FAST (face, arm, speech and time) test:

- **Face**

Ask him to smile or show you his teeth. Is one side of the mouth lower than the other?



- **Speech**

Ask him to repeat a simple sentence after you.

Does he have problems to pronounce the words?



- **Arm**

Ask him to lift both arms. Is he able to do this? Can he maintain this posture? Are his arms steady? Is one arm lower than the other?

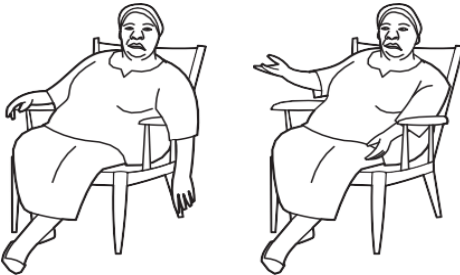

- **Time**

Try to find out for how long he is experiencing these complaints.

A stroke is very likely if the ill person has difficulties with any of these actions.

## 2.3 Choking



Choking occurs when breathing gets difficult or stops because a foreign object is blocking the throat. Infants and children often choke on foreign objects such as coins and small toys. Most adult cases of choking occur while eating.



### What do you see?

- The ill person is trying to cough something up;
- He cannot speak or make any sound;
- He puts his hands on his throat;
- His lips and tongue start to turn blue;
- The veins in his face and neck stick out;
- He becomes dizzy and loses consciousness.



### What should you do?

Ask the ill person: "Are you choking?"

There are two options:

#### 1. He can answer, cough or breathe

- Tell him to keep coughing;
- Do not do anything else.
- Stay with him until he breathes normally again.

## 2. He cannot speak, cough or breathe

- Give 5 blows to the back ('Technique: Blows to the back' page, see below).
- After each blow, check if the object is still stuck, by making eye contact.
- If the ill person can breathe again, stop giving blows to the back.
- Give 5 thrusts to the abdomen (see 'Technique: Abdominal thrusts' page 40).
- If he is still choking, switch between 5 blows to the back and 5 abdominal thrusts.
- If he loses consciousness, carefully place him on the ground.
- Seek help (page 22)



## Technique: Blows to the back

### For anyone over the age of 1

- Stand to the side and a little behind the ill person.
- Support his chest with one hand and bend him well forward. In this way, the object will come out if dislodged and will not move deeper down the airway.
- Give 5 sharp blows between the shoulder blades with the heel of your hand. Each blow should be intended to dislodge the object.
- Check to see if the object has moved or comes out (when this happens, the ill person will be able to speak, cough and breathe again).



### For a baby younger than 1 year old

- Lay the baby along your forearm and give up to 5 firm blows on the





## Technique: Abdominal thrusts

### For anyone over the age of 1

- Stand behind the ill person and wrap both arms around him.
- Make a fist with one hand and place it between his belly button and the lower tip of the breastbone.
- Place your other hand on top of your fist, gripping the back of your hand and wrist.
- Bend the ill person forward and pull your fist strongly towards you

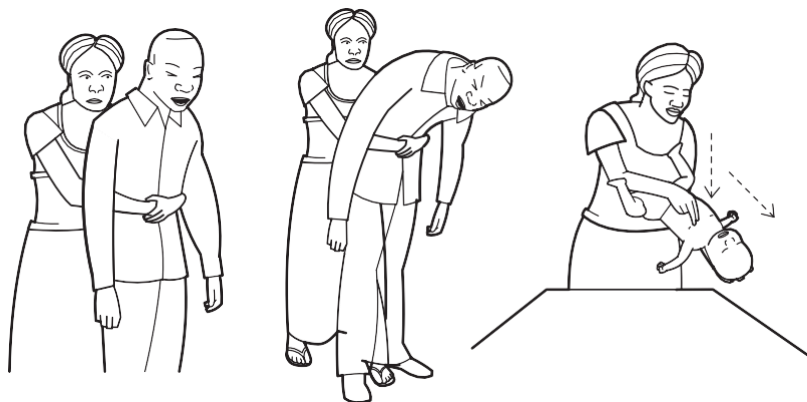

### For a baby younger than 1 year old

- Give chest thrusts.  
To do this, place two fingers in the middle of the chest and push sharply inwards and upwards towards the head.

Abdominal and chest thrusts can cause serious internal injuries. Persons who have been given these thrusts need to be seen by a doctor.



## Prevention

- Take small bites and chew food thoroughly. while eating.
- Teach children not to talk, laugh or cry with food in their mouths.
- Do not lie down, walk, run or jump

- Watch children and prevent them from putting small objects into their mouths (nuts, sweets, fish bones or small toys).
- Do not give liquid to a child who is lying down.

## 2.4 Chest discomfort



If someone complains of chest discomfort, it may be a sign that not enough blood is going to the heart. This is very serious and can lead to a heart attack. Most commonly, a heart attack occurs when there is a blockage in the arteries that carry blood rich in oxygen to the heart. The muscle cells of the heart start to die as soon as they stop receiving oxygen.



### What do you see?

The ill person may experience:

- discomfort, pain or tightness in the chest;
- pain spreading to the shoulder, neck, jaw, arm or stomach;
- difficulty breathing;
- sweating;
- nausea or vomiting;
- dizziness and fainting;



### What should you do?

- Seek help (see page 20).
- Help the ill person into the most comfortable position, for example a sitting or half-sitting position.

Make him rest and ask him not to move. Comfort him and tell him what is happening.



- Ask him if he is taking medication and has taken it according to prescription. Do not delay getting formal medical attention.
- Only if the legislation in your country allows you to give aspirin:  
Make him chew an aspirin and swallow it with water afterwards. Tell him that this will help to get blood to the heart.

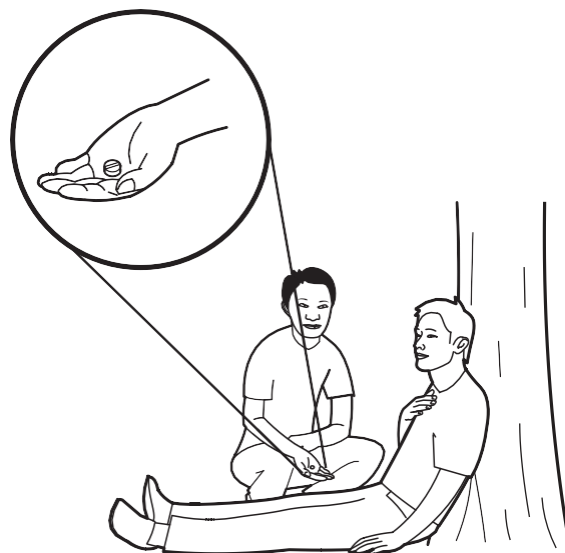

- Arrange urgent transport to medical care yourself if you are alone.
- Keep checking consciousness and breathing. In case he becomes unconscious (see page 29) or is no longer breathing normally (see page 32), give the appropriate first aid.
- Stay with him until medical help is available.

## 2.5 Severe bleeding and shock



Bleeding is the escape of blood from injured blood vessels. Bleeding can be external (open wounds) or internal (bleeding inside the body). A person who is bleeding heavily can die if you do not help him immediately by stopping the flow of blood.

### 2.5.1 Severe external bleeding



#### What do you see?

- The injured person has an open wound that is bleeding severely.



#### What should you do?

- Seek help (see page 20).
- Check if there is no object stuck in the wound.  
If there is, do not remove it  
(see 'Skin wound with embedded object' page 64).
- If the injured person is conscious,  
ask him to press on the wound himself.



- Help him to lie down or give him a comfortable position.



- Put on disposable gloves, or cover your hands with plastic bags to avoid contact with blood.

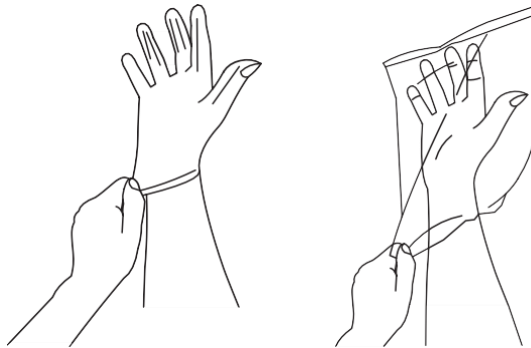

- Using a clean cloth, press on the wound with both hands. If the wound keeps bleeding, press harder. Keep pressing on the wound until help arrives.



- You can wrap a bandage around the wound to slow down the bleeding.



- Bandage the wound firmly but not tightly. A bandage on a limb that is too tight can cut off the blood supply and cause the person to lose that limb.

If the area below the bandage changes colour, starts to swell or the injured person complains of numbness in that area, you will have to loosen the bandage a little. Do not remove the bandage, as the bleeding will start again.



- If the wound bleeds through the first bandage, never remove the bandage, just add another bandage on top and continue to apply pressure.

- Prevent the injured person from going into shock by removing any wet clothing, covering him with a blanket and keeping him warm, but do not overheat him.



- Arrange urgent transport to medical care yourself if you are alone.
- Keep checking for consciousness and breathing.
- Stay with the person until medical help is available.
- Wash your hands after giving first aid. Use soap, or alternatively, ash.



- Do not raise the legs of the injured person. The effect is very limited and in some cases, it might cause harm.
- Do not try to stop the blood flow in a limb using a tourniquet or very tight bandages. If the blood flow to a



## Prevention

- Do not clean up broken glass or pottery with your bare hands. Use hard gloves or kitchen utensils.
- Wear gloves when you want to work with wooden materials that can splinter or when using sharp tools.
- Wear suitable protective materials when using sharp tools.
- Store sharp objects and working tools out of reach of children.
- Pass scissors or knives to other people handle-end first.



## 2.5.2 Internal bleeding



### What do you see?

Suspect bleeding inside the body if the injured person:

- is losing blood from body openings;
- is breathing rapidly;
- has a cold and clammy skin that is pale or turns blue;
- is behaving in an irritated or unusual way;
- becomes sleepy or unconscious.



### What should you do?

- Seek help (see page 20).
- Keep the injured person warm to prevent shock.
- Stay calm and reassure him.
- Repeatedly check for consciousness and breathing.

## 2.5.3 Shock

Shock is a general term used to describe a lack of blood reaching the major organs and tissues, thus depriving them of oxygen. The causes are broad and include:

- blood loss;
- injury;
- heart infarction;
- obstruction of major blood vessels;
- toxins.



### What do you see?

The ill person may:

- show signs of severe external or internal bleeding (see page 41 and 45);
- feel drowsy, confused, unwell and dizzy when standing up. This feeling does not improve when he lies down;
- turn pale, start to sweat and shiver and have cold hands or feet;
- feel nauseous and might feel like vomiting;
- show faster and more shallow breathing;
- eventually lose consciousness.



### What should you do?

- Let the ill person lie down or relax in a comfortable position and talk to him gently and quietly.
- Determine and treat the cause of the shock (for example, try to stop any bleeding).
- Remove any wet clothing and cover him with a blanket to keep him warm.
- Keep checking that the condition is not getting worse and get help as soon as possible.
- Do not give him anything to eat or drink, although, you can wet his lips if he asks for water.

## 2.6 Poisoning



A poison is any substance that causes temporary or permanent damage to the body. Poisons can enter the body through several routes. You can:

- swallow them;
- breathe them in;
- inject them or get injected;
- absorb them through the skin.



### What do you see?

Depending on the type of poison, the ill person may experience these signs immediately or after some time:

- vomiting;
- cramps;
- very large or very small pupils;
- burns in the mouth or throat;
- headache and disturbed consciousness (fainting, dizziness) or loss of consciousness;
- difficulty breathing: too fast, too slow, shallow. Sometimes, the ill person may stop breathing;
- heart palpitations or cardiac arrest;
- signs of shock (see page 46);
- discoloration of the skin;
- sweating;
- muscle twitching or seizures.



## What should you do?

- Seek help (see page 20).
- Place the ill person on his left side. This will reduce the absorption of poison in the body.



- Find out what poison he has taken or has been in contact with, and if possible, when it happened.



- Arrange urgent transportation to medical care yourself if you are alone.
- If this is safe, show the container of the poison to the doctor or write down what is written on the label.



- Avoid contact with any poisonous material yourself!
- Do not give the ill person anything to eat or drink and do not induce vomiting, unless a nurse or doctor advises you to do so.



## Prevention

Most accidental poisonings occur at home when parents and caregivers are not paying attention to the children in their care.

- Teach children about the dangers of substances that contain poison.
- Store all medicines in their original packaging in a safe place, out of sight or reach of children. Bring old medicines that have expired to a healthcare facility, so that nobody is tempted to use them again.

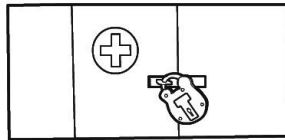

- Avoid taking medicine in front of children because they often copy adults. Never tell children that medicines are 'sweets'.
- Take or give medicines in a well-lit environment so that you know you are taking the correct amount of the right medicine.
- Store household cleaning products, pesticides, fertilisers and paraffin out of reach of children, preferably in child-resistant containers.

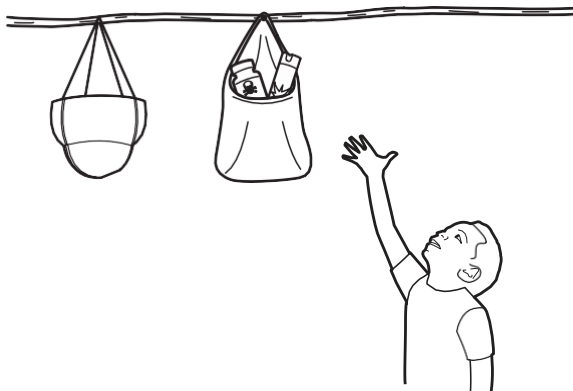

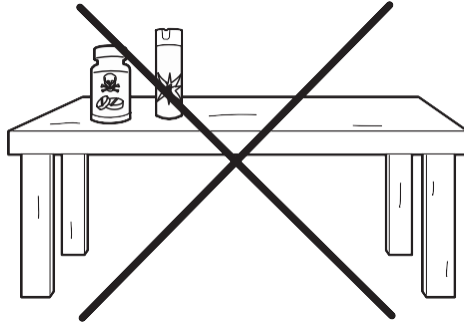

- Check poison containers and make sure they are correctly and clearly labeled and locked away.
- Never use food containers or old soda bottles to store poisonous substances.
- Only re-use containers for domestic use if they are clean, as containers may have contained pesticides.
- Never put insecticide powders or rat poison on the floors of your home; choose a place out of reach of children. Mouse traps, spring traps or glue traps are generally safe.
- Identify poisonous plants in and around your house and place them out of reach of children or remove them. Never eat fruits, berries, mushrooms or plants in the wild unless you are sure that they are not poisonous.
- Do not handle chemicals used on the farm with your bare hands.

## 2.7 Emergency child birth



In the last part of pregnancy, an expectant mother can go into labour at any time. As a first aider you may be required to assist with the delivery of a baby during emergency childbirth.

### 2.7.1 During labour and the pushing stage



#### **What do you see?**

The following signs indicate that labour has started and the baby is coming:

- painful contractions occurring at increasingly shorter intervals;
- the waters break;
- sticky discharge;
- abdominal discomfort;
- local back pains.



## What should you do when labour starts?

- If there is a medical centre in the area, it is best to arrange immediate transportation to the clinic. If not, send someone for the help of a skilled attendant.
- If available to you, take your delivery kit, containing:
  - Soap;
  - Gloves;
  - Materials for cutting the cord (see page 60);
  - Other objects to guarantee clean delivery and prevent infections of the baby.
- Encourage the expectant mother's companions and relatives to be involved. Praise and encourage the mother. Protect and respect her privacy.
- Massage the woman's back to help relieve the pain.
- Encourage the woman to move around and find the most comfortable position.



- Let her urinate often. This will help make more space for the baby.
- Encourage the woman to drink water during labour. She can also eat a little food to keep up her strength.
- Encourage her to breathe out slowly and loudly, and to relax with each breath. Suggest breathing more slowly if she feels dizzy, unwell or tingling in her face, hands or feet.
- Seek medical help immediately if:
  - the baby presents with buttocks or feet first, instead of its head first;
  - there are no contractions 6 hours after the water broke;
  - the contractions continue for more than 12 hours;
  - the woman is bleeding or has a fever (see 'Fever' page 110).



- Do not leave the woman alone.
- Do not use any remedies or medications to speed up labour or to clear out the bowel, unless a midwife or doctor has told you so.



## What should you do during the pushing stage?

- Help the woman into the most comfortable position.
  - An upright position is best, but a lying position is the least challenging to assist with delivery.
  - If the woman lies on her back, it is best to put a small pillow under the right hip. Thereby, you prevent the baby from pressing on important blood vessels.

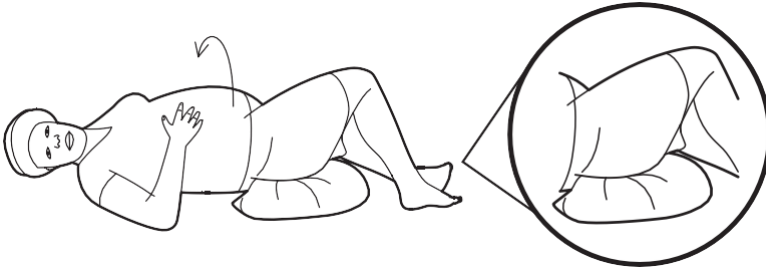

- Wash your hands before giving first aid. Use soap, or alternatively, ash. Put on disposable gloves or plastic bags to avoid contact with bodily fluids.
- Naturally, at this stage the mother feels the urge to push. If the pushing is not working, tell her to change position and empty her bladder. Tell the woman not to push when the baby's head is being delivered.
- Watch the baby come out while supporting the baby's head and shoulders. Do

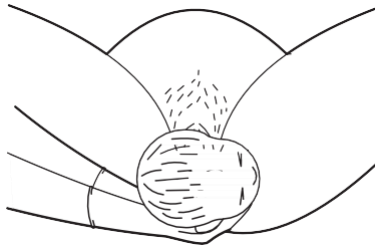

- Do not push on the woman's belly during labour or after delivery.
- The majority of babies are born headfirst, which is normal, but there is the possibility of abnormal presentation in some babies. If anything else than the head is protruding when the baby is coming out (other body parts or the cord) this requires urgent medical assistance.

## 2.7.2 After delivery



### What should you do when the baby is born?

- Immediately place the baby on the mother's bare chest or abdomen so that they have skin-to-skin contact.



- Cut the baby's cord:

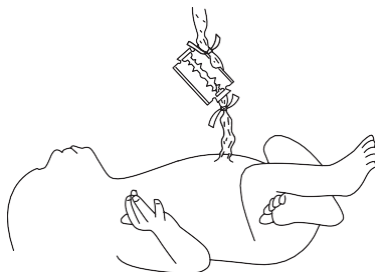

- Use 2 long ties and a clean knife, scissors or razor blade. The equipment you use to cut the cord should be sterilised. This can be done by boiling the equipment in water for at least 10 minutes or running it through a flame a few times.
- Tie the first knot 2 cm (2 fingers) away from the baby's abdomen.
- Tie the second knot 5 cm (5 fingers) away from the abdomen.
- Add another tie on the side of the baby, if the cord continues to bleed after it has been cut.
- Keep the cord dry and clean. Do not put any substance on the baby's cord or stump. This could lead to infection!
- Wipe the baby clean and dry.
- The mother and baby must be kept warm and close together. The baby can be dressed or wrapped.

- The placenta or afterbirth will come out naturally on its own. When it is delivered, put it somewhere safe until it can be disposed of properly. Do not try to pull out the afterbirth by pulling the cord. If the placenta rips, it may cause infection.

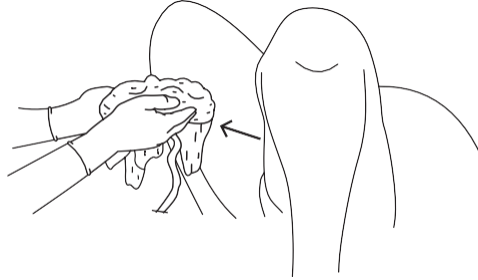

- Wash your hands. Use soap, or alternatively, ash.
- Encourage breast-feeding immediately after birth. Although there is no breast milk, the baby's sucking will stimulate the production of the milk. Breast-feeding helps the placenta to come out and prevents bleeding of the mother after delivery.



- Encourage the mother to move around as soon as she feels able and ready.
- Do not leave the mother alone during the first 24 hours.
- The mother should always seek medical attention.



## What should you do if the baby is not breathing or is struggling to breathe?

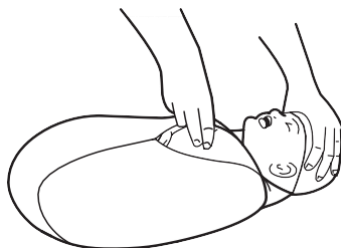

- Move the baby to a clean, dry and warm surface.
- Tell the mother that the baby is having problems breathing and that you will help him to breathe.
- Keep the baby wrapped up warm.
- Start CPR within 1 minute of birth (see page 31).
- Stop resuscitation after 20 minutes if the baby is not breathing or gasping for air. Explain to the mother what has happened and offer your support.



## What should you do if the mother is bleeding heavily after delivery?

- Seek immediate medical help.
- Massage the belly firmly below



- Ask the mother to urinate, if possible.

These actions can help to slow down the bleeding.



## When should you seek medical help for the mother?

- The mother should always seek medical attention after delivery.
- Take her to the hospital or health centre without delay, day or night, if she has any of the following danger signs:
  - Fever (see page 110) and weakness and unable to get out of bed;
  - Pain in the belly and/or bad smelling substance from the vagina;
  - Sudden bleeding or increasing loss of blood;
  - Fits;
  - Difficulty breathing, fast breathing or chest pain;
  - Irregular heart beat;
  - Terrible headaches and blurry sight;
  - Nausea, vomiting;
  - Faintness, dizziness;
  - If the afterbirth is incomplete or has not been delivered 1 hour after the birth of the baby.



## When should you seek medical help for the baby?

- A newborn baby should always get medical attention.
- Seek medical help without delay, day or night, if the baby:
  - is very small;
  - has difficulty breathing;
  - has fits (see page 110);
  - has fever (see page 104);
  - feels cold;
  - is bleeding from the cord stump;
  - is not able to breast-feed.

## 2.7.3 Promotion of safe pregnancy

To prevent complications during pregnancy or harmful situations for either the mother or baby:

- If possible, encourage pregnant women to go to the health centre at least 4 times during their pregnancy and ask a health worker about:
  - vaccinations;
  - healthy diet;
  - which measures to take to prevent diseases that can endanger the health of the unborn child.
- Pregnant women should always follow the advice of the health care worker carefully.
- Pregnant women should also visit the health centre even if there are no problems during their pregnancy.



- If at any time the mother feels sick or has concerns about her health and/or the health of her baby in between the 4 visits, she should visit a health centre immediately. Early detection of a medical problem helps to control the problem better.
- If available, have a safe delivery kit close to hand and make sure that you have it with you when delivering. Even if you have a kit, you still need to go to the health centre for regular check-ups.
- Pregnant women should avoid sleeping on the back and preferably sleep on their sides.

- Pregnant women should always sleep under a mosquito net, as malaria infection ('Malaria', see page 108) during pregnancy can prove a serious threat to the baby's health.

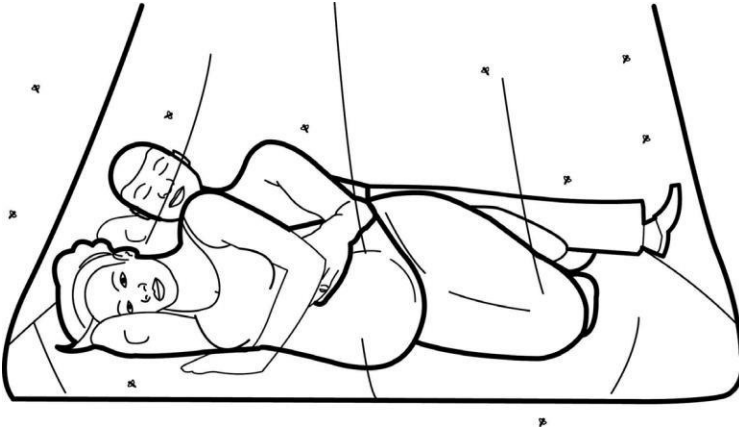



# 3 Injuries

## 3.1 Skin wounds

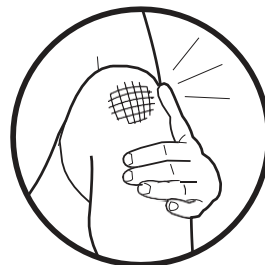

A skin wound occurs when the skin or soft tissue of the body gets damaged. There are different kinds of wounds, which are caused by different things. For example, someone who tries to jump over a barbed wire fence might have a laceration (cut) where the skin and tissues have been torn open. Skin wounds are frequently accompanied by bleeding.

### 3.1.1 Skin wound without embedded object



#### What do you see?

- Damaged skin or tissue;
- Bleeding from the open skin or tissue;
- Discolouration of the skin;
- The injured person may feel pain.



## What should you do?

- Wash your hands before giving first aid. Use soap, or alternatively, ash.
- Put on clean disposable gloves or cover your hands with clean plastic bags.

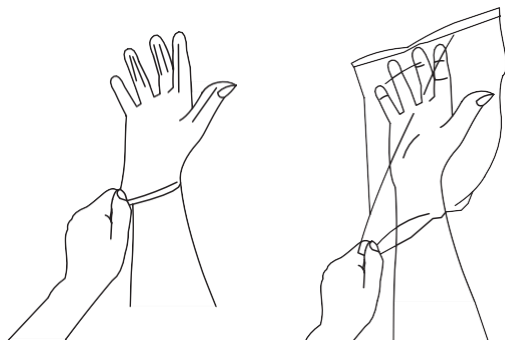

- If the wound is not bleeding a lot:
  - Clean the wound by pouring clean water over it and use wet gauze or a clean cloth to carefully remove any dirt left in the wound.

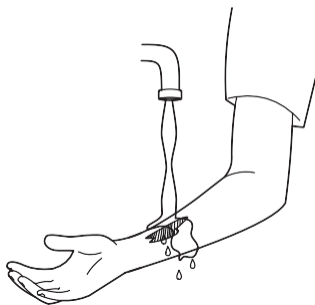

- Cover the wound with a clean cloth, dressing or adhesive plaster to protect it from germs or more dirt.

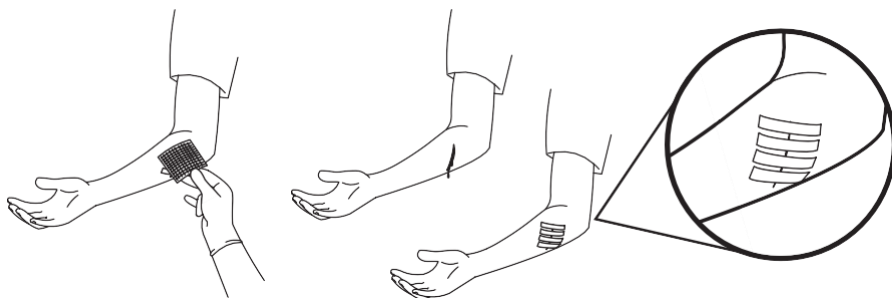

- If the wound is bleeding a lot:
  - Do not waste time cleaning the wound. Your priority is to stop the bleeding. Apply pressure and maintain pressure until the injured person receives full medical treatment ('Severe external bleeding', see page 47).
- Wash your hands after giving first aid. Use soap, or alternatively, ash.
- Tell the injured person or the person caring for him to keep the wound dry. Do not allow flies to touch the wound. Keeping the wound clean will help, as a bad smell attracts flies.
- Every 2 or 3 days, rinse out the wound with clean water and change the dressing. If the wound is infected, clean it every day.



- Even small wounds need attention to prevent infection.
- If a dressing needs to be changed, do not tear the old one off as this can damage the healing wound. Instead, put enough water on the old dressing to take it off easily.
- It is not good to try to close a dirty wound.

### 3.1.2 Skin wound with embedded object



#### What do you see?

- The injured person has a skin wound in which a foreign object is embedded;
- Even if you cannot see an object, something might be stuck in the wound if:
  - the person feels pain in a specific area;
  - he has a painful lump;
  - he has the feeling that something is stuck in the wound;
  - there is a discoloured area.



#### What should you do?

- Seek help (see page 20).
- Put on rubber gloves or use clean plastic bags to protect yourself.
- Do not remove the object as the bleeding will increase if you do so. Try to stop or slow down the bleeding. Be careful not to push the object deeper.
- Try to stop the object from moving:
  - Use sterile gauze to cover the wound, or use a clean dry cloth.

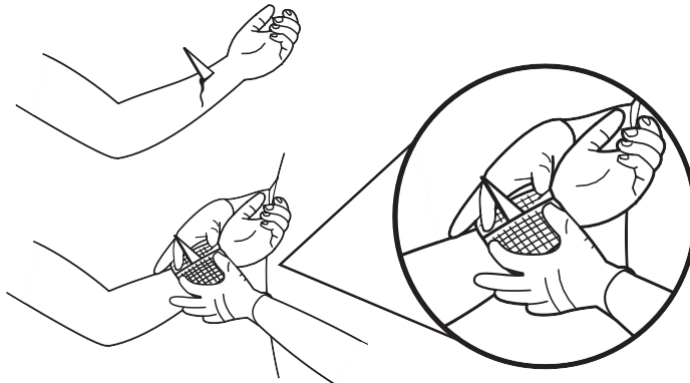

- Build up padding with dressings on the sides of the object until you can bandage over it without pressing down.

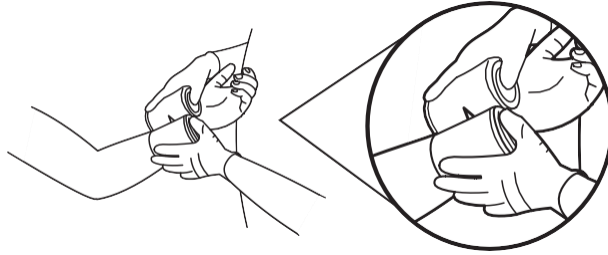

- Bandage this in place without disturbing or putting pressure on the object.

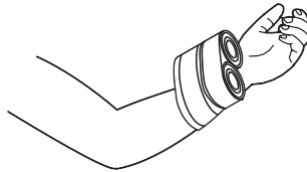

- Take off jewelry or anything else in the area of the wound that may cut off blood flow because of swelling.
- Arrange urgent transport to medical care yourself if you are alone.
- Stay with the injured person until medical help is available.
- Keep checking for consciousness and breathing.
- Wash your hands after giving first aid. Use soap, or alternatively, ash.



## Prevention of bullet wounds

- Store handguns or other firearms in a locked cupboard or box, when not carrying or using them, so that they cannot be accessed by children, or people who would use them improperly. Be sure that children do not know where you have stored them. Store the weapons unloaded, with the safety catch on and store ammunition separately, in a cool dry place away from heat and fire.

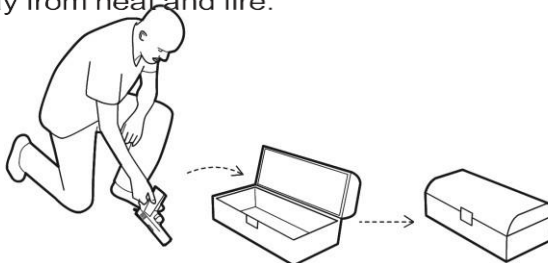

- When carrying a gun, always keep it pointed in a safe direction. Always keep it unloaded and keep your finger off the trigger until ready to use. If you want to shoot, be sure to know what is beyond your target.
- Do not check to see if a gun is empty by firing it.
- Firearms should not be used as a warning device. If you do so, be aware that they can kill.

### 3.1.3 When should you seek medical help for a skin wound?

Most cuts and grazes can easily be managed at home. However, you should seek medical help if:

- you cannot stop the bleeding;
- an object is stuck in the wound;
- the wound has an irregular shape, is gaping open or is bigger than half the width of the injured person's hand;
- the injured person is losing feeling or has problems moving the body part;
- the wound is on the face, on or near the eyes, or in the area of the sex organs;
- the wound has dirt in it and cannot be cleaned properly;
- the wound has faeces or urine in it;
- the wound was caused by a bite;
- the injured person has diabetes or an immune disease;
- the injured person is 65 years old or older;
- it is more than 10 years since the injured person last had a tetanus injection or if there is any doubt about when the person last had a tetanus injection. Even small wounds can cause tetanus. It is very safe to get a tetanus injection.

It is best that wounds are managed within 6 hours. Do not delay seeking medical help.

Tell people to **watch out for infection** during the following days and get medical help if there is any sign of infection, such as:

- pain that is getting worse;
- fever (see page 110) or a feeling of being unwell;
- swelling, hot or red skin around the wound.

It is normal to have some light wound response. Get medical help if the wound increases or is associated with signs of infection.

## 3.2 Burns



Burns occur when the skin and body tissue is damaged by heat, chemicals, radiation or extreme cold.

There are 3 types of burns, depending on the depth of the burn:

1. Superficial burns;
2. Partial-thickness or intermediate burns;
3. Full-thickness or deep burns.



### What do you see?

- Superficial burns
  - The skin is red (or darker than usual), slightly swollen and painful.
- Partial-thickness or intermediate burns
  - You also see blisters.
  - The injured person is in a lot of pain.
- Full-thickness burns or deep burns
  - The burn can look black, parchment-like or white.
  - There is usually no pain in the wound, because the nerves in this area have been destroyed. However, the skin around the wound remains painful.



## What should you do?

- Seek help (see page 20).
- If the injured person's clothing is on fire, stop him from running around. Pour water over him, wrap him in a heavy blanket or make him roll on the ground.

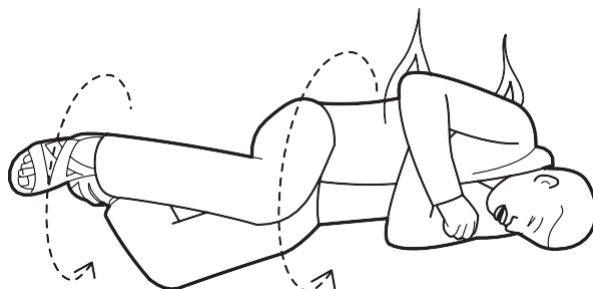

- If possible, use clean water to cool the burn. Otherwise use any water. Pour cool water on the burn for 15-20 minutes, or until it stops hurting. Even if it hurts less after a while, keep cooling in total for at least 10 minutes. Cooling not only reduces pain, but also prevents a burn from going deeper by taking heat away from the skin.

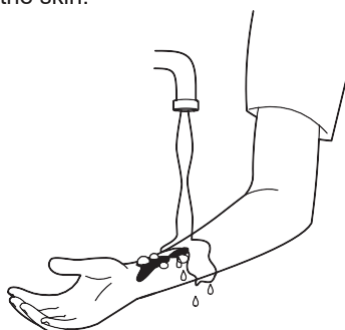

- Put on gloves or cover your hands with clean plastic bags.
- Remove any clothing and jewellery, but only if these are not stuck to the skin.
- You can put cold liquid honey on the burn. This prevents infection and helps the wound to heal. Alternatively, you can also use aloe vera.

- Cover the burn with a sterile wet wound dressing. Use sterile or clean tweezers to do so. Only use dressings that will not stick to the burn.

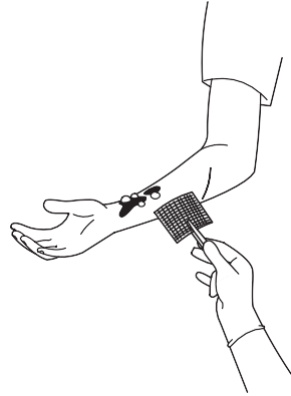

- Bandage the dressing to the wound.



- Wash your hands after giving first aid. Use soap, or alternatively, ash.



- Protect the injured person from hypothermia:
  - Try not to use very cold water during cooling;
  - Protect him from the wind and wrap him in blankets.
- Do not use toothpaste, creams, oil, butter or soap on burns. They can trap the heat in the burn, causing the burn to be worse, and might cause infections.
- Do not open or break blisters (this creates an open wound vulnerable to infection).
- Keep flies and other insects away from the wound to prevent infection.



## When should you seek medical help?

Minor burns can normally be safely managed at home. However, you must immediately seek medical help if:

- the injured person is under 5 years old or over 65 years old;
- the burn is on the face, ears, hands, feet, the sexual organs or joints;
- the burn circles an entire limb (an arm or a leg), body or neck;
- the burn is equal or larger than the person's hand size;
- the burn looks black, white, papery, hard and dry;
- the injured person has no sense of feeling in the wound;
- the burns were caused by electricity, chemicals or high-pressure steam;
- the injured person has inhaled flames or heat or breathed in a lot of smoke;
- his clothing or jewellery has stuck to burnt skin;
- it is (likely) more than 10 years since his last tetanus injection;
- in the days after, the burn smells bad, is soaked with pus or the injured person gets a fever (see page 110).



## Prevention of burns

- Teach children about household objects that can cause burns and instruct them about the danger of fire.
- Never leave children alone near heat sources, hot water and open fires.

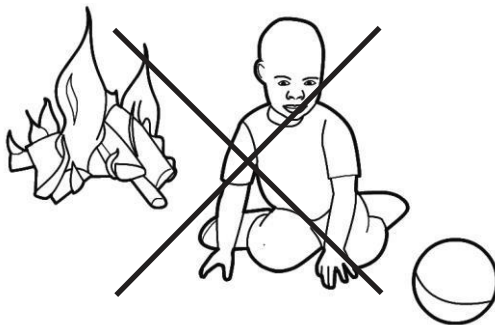

- Install guards around open fires and electric, gas or coal heaters to discourage children from standing too close.
- Never leave food unattended on a stove.
- If you cook outside, raise the level of the stove and build mud barriers.
- Turn pot and pan handles toward the back of the stove, so that children cannot accidentally knock them over. Do not leave spoons or other utensils in pots while cooking.
- Avoid wearing loose clothing that could catch fire and keep cooking areas free of flammable objects.
- Keep hot drinks away from young children.
- When bathing, avoid using too hot water. Check the temperature with your elbow.
- Store all matches, lighters and flammable material, such as kerosene (paraffin), safely and out of reach of children (preferably outside the home or living areas).
- Be careful when handling chemical products, as contact with these can result in burns. Always read the instructions and wear protective clothing, such as gloves and safety glasses.



## Prevention of fire

- Never leave candles unattended. Keep them in a sturdy holder, that cannot catch fire and keep them away from flammable materials.
- Be careful handling paraffin stoves and lamps as they can easily be knocked over and ignite.
- Maintain a good pressure on a paraffin stove, so that the paraffin does not leak outside the stove.
- Never smoke in bed or leave burning cigarettes unattended. Do not empty smouldering ashes into a trash can, and keep ashtrays away from clothes.
- Pour water or sand on smouldering ashes after cooking.
- In case of fire you can use fire extinguishers, or alternatively sand buckets, to quickly extinguish the fire.
- Be aware of danger when burning bushes.
- Do not pour petrol or paraffin on top of wood, when making a fire.
- Remove electrical cords from floors and keep them out of reach. Be careful with wires that are exposed and electrical instruments near water. Exposed wires or bad connections can cause fire.

## 3.3 Stings and bites



Animals can either sting or bite people. In most cases, the consequences of these stings and bites are rather mild. However, bee and wasp stings can be life-threatening because of allergic reactions. Moreover, some types of snake, spider or scorpion venom can result in death.

### 3.3.1 Bee or wasp



#### What do you see?

The injured person may suffer from:

- Local swelling and redness of the skin;
- Itching and pain where the insect has stung;
- Headache and dizziness;
- Nausea and vomiting;
- Difficulty breathing;
- Loss of consciousness.



## What should you do?

- Remove the sting as soon as possible. This can help to keep the bite smaller. Use your fingers or whatever you have at hand to remove the sting.



- Wash the bite with water.

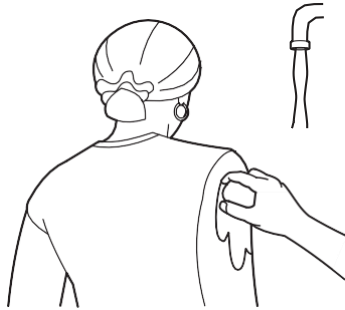

- Wrap a piece of ice in a cloth or towel and apply it to the sting area to reduce swelling and pain. If you do not have ice, use cold water. Do not cool for more than 20 minutes at a time.

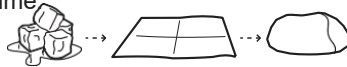

Do not scratch the bite: this can cause infections, especially when the nails are dirty.



## When should you seek medical help?

- If the person is allergic to bee or wasp stings, this is a life-threatening situation. Seek emergency medical help if the injured person suffers from the following symptoms right after being stung:
  - rapid pulse, dizziness or feeling faint;
  - swelling or itching anywhere else on the body;
  - **breathing;**
    - difficult
    - headache;
  - **difficult** swallowing, or swelling of the face or mouth;
  - vomiting.
- Seek medical attention if the sting is very painful.



## Prevention

- Keep away from flowering plants, ripe fruit bushes and trees, rotten fruit, compost and food waste. If this is not possible, wear long trousers and long- sleeved clothes and cover your hands and face as much as possible.
- Cover your drinks and check food and drinks for bees and wasps before eating or drinking.

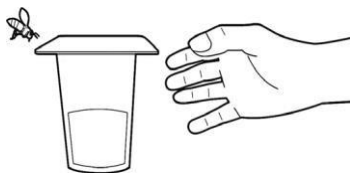

- Do not leave food waste uncovered outside.
- Wipe off food remains on clothes, hands and faces of children, as this may attract bees or wasps.
- Shake out shoes, socks and clothing before wearing as they might contain insects.
- Do not touch or disturb bee or wasp hives. If you want to harvest honey, protect yourself by wearing long trousers and long-sleeved clothes and cover your hands and face as much as possible.
- Remain calm if attacked by a bee or wasp. Do not wave your hands in an attempt to brush them away, since they react to movement.
- Run and find shelter if attacked by a swarm.

### 3.3.2 Snake, scorpion or spider



#### What do you see?

Depending on the species there can be:

- Bleeding, swelling, bruising;
- Numbness, weakness, confusion, affected vision;
- Heart arrest or difficulty breathing.



#### What should you do for a snake bite?

- Seek help (see page 20).
- If it is safe to do so, check what type of snake has bitten the person, but do not try to catch it. If possible, write down a description of the snake (its shape, colours and distinguishing features).
- Watch the injured person for a change in his condition. Evaluating if a snake is poisonous or not is difficult. To be safe, always assume that the snake is poisonous.
- Help the person to lie down and tell him not to move. Offer comfort and keep him calm. This will slow down the venom.



- Try not to touch the person's blood. Put gloves on or cover your hands with clean plastic bags.
- Take off any rings, watches or tight clothing that may cut off blood flow because of swelling. Be careful not to move the limb.
- If venom gets in the eyes, rinse them for 15 to 20 minutes with water, from the nose outwards.



- Has the person been bitten in the arm?  
Tell him to immobilize his own arm by holding it close to his body until he obtains medical care.
- Has he been bitten in the leg?  
Immobilize it by bandaging it to the other leg.
  - Gently bring the good leg to the bitten leg.
  - Use a stick to splint the limb and bandage it in place.

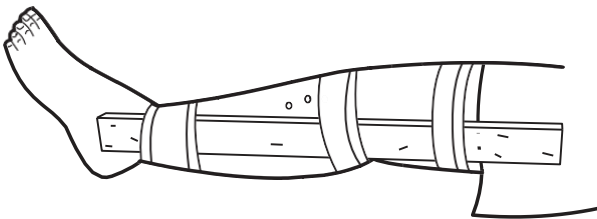

- Arrange urgent transport to medical care yourself if you are alone.
- Stay with the injured person until medical help is available.
- Keep checking for consciousness and breathing.
- Wash your hands after giving first aid. Use soap, or alternatively, ash.



- Do not try to catch the snake.
- Do not try to suck or cut the venom out. Do not rub herbs on the bite. This will not help and can harm the person even more.



## What should you do for a spider bite or scorpion sting?

- Put on rubber gloves or cover your hands with clean plastic bags.
- Wash or wipe away any venom.



- Wrap a piece of ice in a cloth or towel and apply it to the sting or bite to reduce swelling and pain. If you do not have ice, use cold water. Do not cool for more than 20 minutes at a time.
- Find medical help if the pain does not decrease.



## Prevention

- Check all clothing, especially towels and bed sheets, for scorpions and spiders. Shake shoes out before putting them on.
- Sleep under a bed net that is properly hung and tucked under the mattress. Wherever possible, sleep above ground level.
- Maintain a clean domestic environment and seal holes and cracks in walls. In this way, you can reduce the number of hiding places for snakes, scorpions and spiders.
- Store food in sealed containers to keep away small animals (mice, rats, chickens) as they are food for snakes and attract them.
- Keep your environment clean and the grass short around your house.
- Avoid places where snakes may live, for example tall grass, rocky areas, fallen logs, swamps, marshes and deep holes in the ground. Watch where you sit when outdoors. Do not put your hands into areas where snakes, spiders or scorpions may be hiding.

- When walking through tall grass or weeds, wear loose, long trousers and high, thick leather or rubber boots. Poke at the ground in front of you with a long stick to scare away snakes.



- Shine a light on your path when walking outside at night.
- Wear working gloves when selecting firewood, gardening, harvesting or working in an area where snakes, spiders or scorpions are likely to live.
- If a venomous spider lands on you, flick the spider off with a finger, rather than squishing it against the skin.



- Never agitate a snake if it comes nearby. First, keep very still and then slowly move away.
- Never handle a snake, even if you think it is dead, as recently killed snakes may still bite by reflex.
- Never intentionally run over a snake as it may become agitated and attack pedestrians. Moreover, never ride over a snake, as it can wrap itself around the undercarriage of your car and come home with you.

### 3.3.3 Dog, cat, monkey or human



#### What do you see?

You may observe:

- bite marks caused by animal or human teeth;
- laceration wounds to the skin;
- bruising of the skin, resulting in discolouration;
- pain;
- bleeding of the bite wound.



#### What should you do?

- Wash your hands before giving first aid. Use soap, or alternatively, ash.
- Put on your disposable gloves or slip your hands into clean plastic bags.
- If the wound is bleeding severely, stop the bleeding by applying direct pressure.

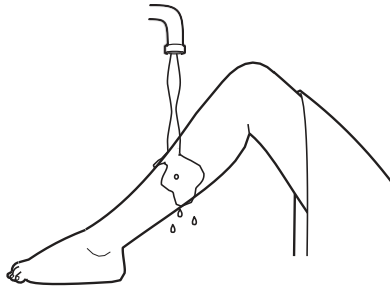

- Cover the wound with sterile gauze or a clean dry cloth.
- Wash your hands after giving first aid. Use soap, or



## When should you seek medical help?

Always seek medical help straight away. A person who has been bitten needs adequate medication to prevent infection. It is also important to be vaccinated for tetanus.



## Prevention of dog bite wounds

- Teach children not to threaten or scare dogs.
- Never leave children alone in the presence of dogs.
- Do not touch dogs that you do not know. Avoid dogs exhibiting unusual behaviour.
- Do not enter a compound where there is a guard dog that is not restrained.
- Do not touch dogs while they are eating, sleeping or playing.
- Avoid running in the presence of a stranger's dog.
- Stand still if you are attacked by a dog. Do not try to run away, but walk away slowly when the dog loses interest.
- Leave your dog alone when it is scared.
- Do not allow your dog to approach strangers without your supervision.

## 3.4 Injuries to muscles, joints or limbs

### 3.4.1 Broken or dislocated limbs

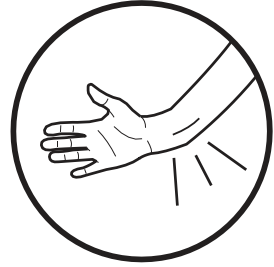

A **broken bone** refers to a bone that may be cracked or partially or completely fractured. A **dislocation** occurs when two bones that come together in a joint (such as the shoulder, hip or knee) have moved in an abnormal way relative to one another.



#### What do you see?

- The limb or joint might be in an abnormal position;
- Severe pain at the site of the dislocation or fracture;
- Difficulty in moving the affected part;
- Swelling and skin discolouration;
- You may see blood and visible bone fragments in an open dislocation or fracture.



#### What should you do?

- Seek help (see page 20).
- If the fracture is bleeding seriously, press down on the bleeding or put on a compression bandage.
- If you think a leg bone is broken, tell the injured person not to stand on it.
- Do not apply bandages if an ambulance is on its way.



- If a limb looks odd or dislocated, do not try to reset it. This may make the injury worse.
- Raising the injured person's leg provides no benefit and can cause pain and further injury. Keep the person still.

- If you suspect a broken arm, tell the injured person to immobilise his own arm, by holding his arm close to the body.  
If he cannot support his own arm, you can turn up the lower end of his clothing and pin this above the arm to form a sling.

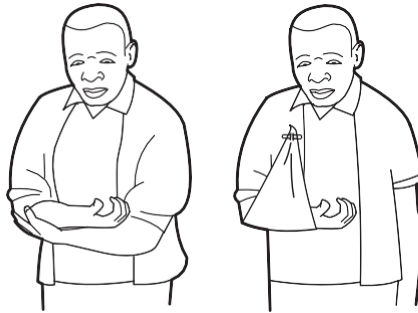

- If the injured person has a broken leg and needs to be transported, keep the leg still by splinting and tying it to the other leg:
  - Carefully move the uninjured leg close to the injured leg;
  - Use padding to fill in hollow areas;
  - Use bandaging or strips of cloth to attach the legs together.

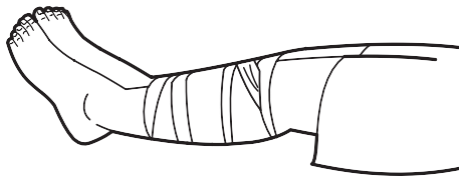

If both legs are broken, you need to use a splint, for example a stick.  
If you use a splint, check that it is not too tight. If the fingers or toes become cold, white or blue, loosen the splint.

- Keep the injured person warm, but do not overheat him.
- Arrange urgent transport to medical care yourself if you are alone.
- Stay with the injured person until medical help is available.
- Keep checking that the injured person is conscious and breathing normally.



## When should you seek medical help?

If you are in doubt as to the severity of the injury, assume that the limb is broken or dislocated and seek medical help.



## Prevention

- Do not leave objects lying on the floor and immediately clean up spilled liquids or food on the ground. Remove electrical cords from the ground and avoid loose carpets. Repair damaged carpets and uneven or cracked floors immediately.
- Pay attention when walking on wet floors or on slippery ground.
- Store things you need frequently within easy reach.
- Ensure good lighting.
- Ensure that stairs are safe, remove loose objects or carpets and use the handrail.
- To prevent children from falling down the stairs, you can use a stair gate or something to block entry at the top or bottom of the stairs. Do not let young children go up and down the stairs alone. Even a few steps can result in a fall.



- Do not let young children climb in trees.
- Ensure that children cannot fall from an open window or balcony. If possible, use window guards and balcony railings.
- Use non-slip mats and arm grips in your shower or bathtub.
- Wear shoes that fit properly. Slippers, smooth soles and high heels can cause you to slip and fall.

### 3.4.2 Injuries to muscles or joints



Sudden unexpected movements like a blow or fall can cause injuries to muscles or joints.



#### What do you see?

- The injured person feels pain at the site of the injury;
- Swelling or discolouration around the affected area;
- Difficulty in moving the affected joint.



#### What should you do?

- Use ice, if you have it, to cool the injury. Ice can reduce the pain and improve the healing. Wrap the ice in a cloth or a towel so it does not touch the skin directly.
- If you do not have ice use cool water.
- Do not cool for more than 20 minutes at a time.

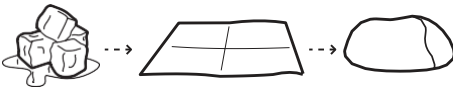

- Do not massage the injury.
- Do not put heat on the injury.
- Do not let the injured person continue his activity.
- Avoid alcohol.



## When should you seek medical help?

Many injuries to muscles or joints can be managed at home. If you are not sure how severe the injury is, it is safer to seek medical help.

Seek immediate medical help in case of:

- Bad bruising and swelling;
- Some loss of feeling;
- Inability to move the limb;
- Very painful and tender joint swelling straight after the injury.

Seek medical care during the following days if:

- The injured person has difficulty walking or making other movements;
- The pain or swelling gets worse;
- The injured person has a fever (see page 104) and a swollen joint that feels warm to the touch;
- The condition of the injured person does not improve.



## Prevention

- **Related to sports**
  - Warm up properly (about 20 minutes) before you start doing sports by stretching your muscles and starting your activity gently.
  - Avoid sporting activities or exercises when you are tired. Take a break when you feel exhausted.
  - Respect the rules of the game.
  - Always wear shoes that support and protect your feet when doing sports or outdoor activities.
  - Wear appropriate protective equipment, such as knee and elbow pads, if you engage in sports.
  - Be careful when running or walking on uneven surfaces.

- **Related to lifting**

- Reduce the load if possible. Ask other people to help you to carry a heavy load.
- At the start of the lift, adopt a posture that gives you maximum balance and reduces the chance of losing your balance when lifting.
- Kneel deep and keep your back straight when lifting a low-lying load. Avoid bending forward without knee flexion when lifting a low-lying load.



- Avoid lateral flexion and extreme rotation of the upper part of the body while lifting.

### 3.5 Injuries to head, neck or back



Head, neck and back injuries are injuries to one or more vertebrae (neck and back bones). They are also referred to as spinal injuries. Spinal injuries can be very serious and should always be managed with caution. The dangers of spinal injuries are:

- Partial paralysis of the body;
- Complete paralysis of the body.



#### What do you see?

Suspect a serious head, neck or back injury if the person:

- has had a hard blow through a road accident or from falling from a height greater than standing height;
- becomes sleepy or loses consciousness;
- does not remember exactly what just happened;
- has a terrible headache that does not go away;
- is feeling sick to his stomach or is vomiting;
- is behaving in an irritated or unusual way;
- has a fit;
- has serious wounds or injuries to the head;
- complains about numbness or tingling sensations;
- has serious injuries on the legs and does not complain about pain;
- feels pain or tenderness in the neck or back.



Seek medical help if you feel unsure about the injury.



## What should you do?

- Seek help (see page 20).
- If the injured person is unconscious (see page 24), make sure that he is breathing freely.  
If the injured person is conscious, calm him and ask him not to move.

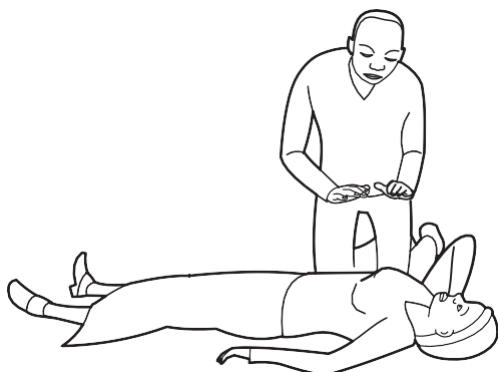

- Keep the head and neck still:
  - Place a tightly folded cloth on each side of his head and neck.



OR

- Only keep the head and neck still if the injured person lets you.  
If he is upset or excited, do not force him to have his neck immobilised.

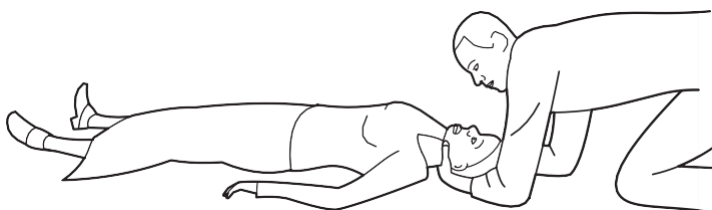

- Keep the person warm, but do not overheat him.



- Arrange urgent transport to medical care yourself if you are alone.
- Keep checking for consciousness and normal breathing.
- Stay with the injured person until medical help is available.



## Prevention of road traffic injuries

- **For car drivers and passengers**
  - Always wear your seat belt while driving. Use a child's seat for children younger than 10 years or as specified by local regulations and make sure it is used properly.



- Whenever possible, place children in the back seats of the car.
- Do not drive the car after drinking alcohol or taking drugs. Do not ride with a drunken driver. Discourage people who are drunk from driving.
- Do not drive the car when you are feeling tired or sleepy. The following can stop you from dozing off:
  - Talking to a passenger;
  - Rolling the window down;
  - Stopping to take a break.

- Always pay attention to the road, do not reach for things or use your cell phone while driving.
- Do not speed, always leave enough space between vehicles and always check traffic when leaving a parking space or overtaking other vehicles.
- Pay attention to cyclists and motorcyclists.
- Regularly maintain your car.
- Avoid using unsafe public transport, such as an overcrowded bus, a vehicle in a bad condition or a vehicle driven by somebody who is tired or drunk.
- Use a seatbelt if available.

■ **For motorcyclists and cyclists**

- Always wear a helmet when riding a bicycle or motorcycle.

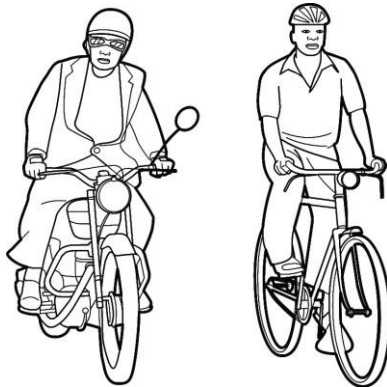

- If cycling or driving a motorcycle at night:
  - use lights so that you can see where you are going;
  - use reflective materials if available, to make sure that you are seen.

■ **For pedestrians**

- Never let children play on the road. Do not allow children below the age of 10 to cross the road unsupervised.
- If the road has no pavement, it is safer to walk on the side of the oncoming traffic.
- Carry a torch to light the road when walking at night.

## 3.6 Eye injuries

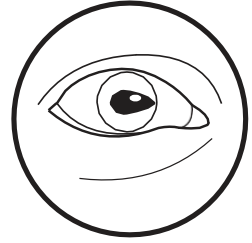

The eye is a person's window to the world. Eye injuries should always be managed with great care.

### 3.6.1 Object stuck in the eye



#### What do you see?

- A foreign body is stuck in the eye of the injured person. Sometimes it is visible, sometimes it is not;
- The eye can be painful;
- The eye is tearing and may appear red;
- Blood or a clear fluid may come out of the eye;
- The person has problems with his vision.



#### What should you do?

- Seek help (see page 20).
- Do not try to remove the object.
- Loosely cover the eye.



- Keep the head as still as possible.
- Cover the good eye as well and ask the injured person to keep it still, because both eyes move together.
- Arrange urgent transport to medical care yourself if you are alone.

## 3.6.2 Speck in the eye



### What do you see?

- The injured person has an abrasive feeling when blinking or moving the eyes;
- The eye is red, tearing and often kept closed by the injured person.



### What should you do?

- Get the injured person to sit.
- Rinse the speck out of the eye from the nose outwards. Use clean water or water that has been boiled and cooled. Water at room temperature is more comfortable than cold water. Warm water might burn the eye.



- If this does not work, cover the eye and seek medical assistance.

### 3.6.3 Blow to the eye



#### What do you see?

- The area around the eye is swollen and shows blue and red discolouration;
- The person may have problems with his vision;
- The person cannot keep his eye open;
- The eye itself might be hurt.



#### What should you do?

- Make a cold compress:
  - Put ice in a plastic bag and wrap it in a cloth
  - OR
  - Soak a piece of clean cloth in cold water and squeeze it out.

- Make sure the eye is fully closed when applying the cold cloth.  
Put this cold compress loosely on the eye as long as the person can tolerate it.

This helps with the pain and keeps down swelling. Do not press hard against the eye.

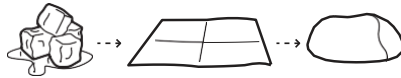

## 3.6.4 Harmful liquids in the eye



### What do you see?

- The skin surrounding the eye is burnt;
- The eyelashes and eyebrows can be scorched;
- The eyes appear red;
- There might be extra films on the eye ball.



### What should you do?

- Seek help (see page 20).
- Rinse out the eye straight away with preferably clean water. Do this for 10-15 minutes, from the nose outwards so that none of the liquid runs out from one eye into the other.



- Arrange urgent transport to medical care yourself if you are alone.

### 3.6.5 When should you seek medical help?

Immediate medical help is needed for eye injuries if:

- a harmful liquid has entered the eye;
- a speck cannot be removed or if an object (even very small) is stuck in the eye;
- the vision is affected.

If the condition of the eye gets worse in the days after, the injured person should seek immediate help. Signs to look for:

- Pain is getting worse;
- Vision that is getting worse;
- Condition of the eye is not getting better after 3 days.

### 3.6.6 Prevention

- Wear safety glasses, goggles, or face shields when you hammer nails or metal and work with power tools to protect against flying fragments, dust particles and sparks.



- Use chemical goggles to guard against exposure to splashing fertilisers, pesticides and chemicals.
- If you are welding or near someone else who is welding, wear a mask or goggles designed for welding.

- Protective eyewear can prevent sports-related injuries. Wear proper safety goggles during sports that carry the risk of eye injuries such as racquet sports.
- If you go fishing, be careful when handling and throwing the fishing line, because the fish hook is very sharp and can easily become embedded in your eye.
- Do not let children throw stones and tell them to be careful of their eyes when playing with sticks.
- If you have lost one eye, always wear protection for the other eye, since you are at greater risk of eye injury due to a loss of vision.

## 3.7 Nose bleed



The nose contains small blood vessels that can easily break and start bleeding. Therefore nose bleeds are common as a result of a blow to the nose or head, but also of sneezing, blowing or picking the nose. However, a nose bleed can also occur spontaneously. An increased blood pressure and heat can facilitate this.



### What do you see?

- Blood is dripping or running from the nose. It can also run in the throat;
- If the person has swallowed blood, he may feel nauseous.



### What should you do?

- Ask the injured person to pinch his nose with his index finger and thumb and to lean forwards, breathing through the mouth. If necessary, pinch his nose yourself. Try not to touch the injured person's blood. Use gloves or a clean plastic



- Pinch the nose for at least 5 minutes. If the bleeding continues after this time, pinch the nose again for 5 minutes more. If needed, repeat this until the bleeding stops. Meanwhile the patient should breathe through the mouth.
- It is advised not to blow or pick the nose during the first hours.
- Wash your hands after giving first aid. Use soap, or



## Prevention

- Do not pick your nose or blow your nose hard.
- Prevent children from putting small objects in their nose. Children under the age of 3 are at the highest risk because they explore the environment by putting objects in their mouth or nose.

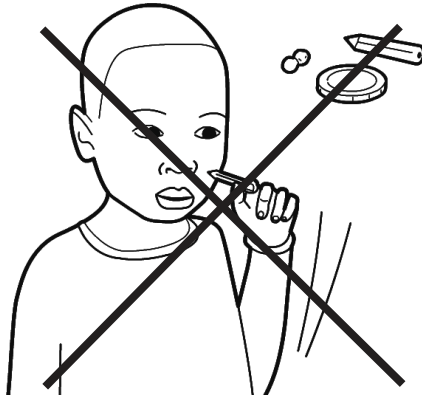

## When should you seek medical help?

In some situations, a nose bleed can be serious and lead to death. You should seek medical help if:

- the bleeding does not stop;
- the nose bleed was caused by a punch to the nose, a fall, a road accident;
- blood spurts from the nose;
- the injured person becomes sleepy or becomes unconscious.





# 4 Illnesses

## 4.1 Fainting



Fainting is a brief and sudden loss of consciousness. This happens when there is a temporary shortage of oxygen in the brain, due to a decreased supply of blood to the brain.

Fainting may be caused by many reasons, such as:

- emotional distress;
- tiredness;
- hunger;
- standing for a long period of time;
- a sudden change in body position;
- spending a long time in hot environmental temperatures;
- specific medical conditions.



## What do you see?

The ill person may:

- have a pale skin;
- feel dizzy and see black spots or stars;
- hear a murmur;
- feel weak and sometimes nauseous;
- start to sweat, but his skin feels cold;
- yawn;
- feel a tingling sensation in the fingers;
- eventually lose consciousness and fall down.



## What should you do?

- Let the ill person lie down on the ground.
- Make sure he gets enough fresh air and let bystanders keep a distance.
- Loosen clothing that may make it hard to breathe.
- Put cold compresses or a wet cloth onto the forehead of the ill person.
- Once he regains consciousness, let him lie down for a couple of minutes. Gradually let him sit upright and stand up. If he feels weak again, let him lie down again until he is fully recovered.
- Find out if the ill person has injured himself while falling down. Act according to your findings.
- If the ill person does not regain consciousness within 2 minutes, put him into the recovery position (see page 25). Give first aid for unconsciousness (see page 24). Check for consciousness and breathing each minute.



## Prevention of fainting

- Avoid stress, tiredness and hunger.
- Do not stand up quickly from a lying or sitting position.
- Avoid standing for long periods.
- Drink more water and try to avoid physical exertion in case of being in a hot environment for a long period of time.



## What should you do if you feel as if you are about to faint?

- Lie down.

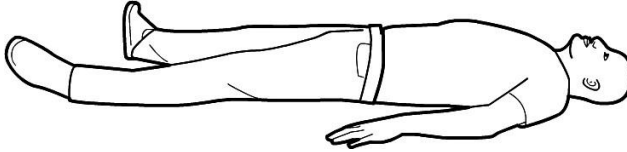

- Sit on the edge of a chair or bed with your head bent forward between your knees.



- Squat.



- Stand with crossed legs, preferably in combination with tensing your leg muscles, by tiptoeing or stretching your legs.

## 4.2 Fever



Fever can be a sign of serious illness. Any person with fever needs medical attention to determine the cause. Fevers caused by malaria (see page 108) or pneumonia can be very dangerous if they are left untreated and can lead to death.



### What do you see?

The ill person:

- is cold, but feels warm;
- sweats, but has goose bumps. He may shiver and chatter one's teeth;
- may feel unwell and have a headache;
- might have muscle pains;
- shows signs of dehydration;
- displays febrile fits (see page 112).



## What should you do?

- Wash your hands before giving first aid. Use soap, or alternatively, ash.
- Find out how high the ill person's temperature is:
  - Use a thermometer in the armpit, if available. The ill person has a fever if his temperature is higher than 37,5 °C.

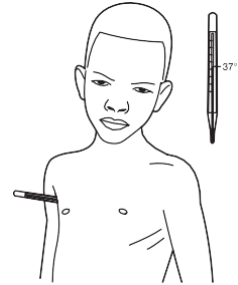

- If you do not have a thermometer, and the person feels hot to touch, is it probably a fever.



- Seek medical help to find out the cause of the fever.
- Someone with fever needs to rest and drink lots of fluids to stop dehydration:
  - Give the ill person more to drink if the colour of his urine is dark and the ill person does not urinate often.
  - Breast-fed babies: continue to breast-feed but more frequently than usual.
  - Bottle-fed babies: continue with normal feeds and give extra rehydration drinks.



- Think about how the ill person is dressed. Dressing too warm can increase the fever, dressing too lightly can cause shivering which will deplete the body's energy.
- Use lukewarm water to sponge the ill person unless it upsets him or causes shivering. Do not use cold water!



- If an ill person is suffering, give an anti-fever medication if this is allowed in your country.



- If the ill person has a fit, give first aid for fits (see page 110).
- Wash your hands after giving first aid. Use soap, or alternatively, ash.
- Keep checking the ill person day and night: get up two or three times in the night to check.



## When should you seek medical help?

- Fever can be a sign of serious illness. Any person with fever needs medical attention to determine the cause. Medical care is especially important for babies, children and pregnant women.
- Seek emergency medical help if the ill person:
  - cannot take medication;
  - has fits;
  - is very sleepy, difficult to wake up, or confused;
  - has a headache;
  - keeps vomiting;
  - cannot drink, urinates less and the colour of the urine darkens, has sunken eyes, cries without tears, has a dry mouth;
  - cannot stand up or sit up;
  - is a baby and is too weak to be carried;
  - has fast breathing (more than 40-50 breaths per minute);
  - has difficulty breathing;
  - has a whistling noise when breathing;
  - is bleeding spontaneously.

If an ill person must travel for help, keep giving him sips or drinks on the way there.



## Prevention

- Get a vaccine against several infections, such as tetanus, measles (see page 120) and tuberculosis.
- Wash your hands after taking care of or having contact with a sick person. Use soap, or alternatively, ash.
- Pregnant women and children should reduce contact with people with a fever.
- If you have a fever, cough into a tissue and always wash your hands carefully afterwards. If no tissues are available, cough into your own sleeve or shirt rather than into your hand, because illness is spread much easier by hands.

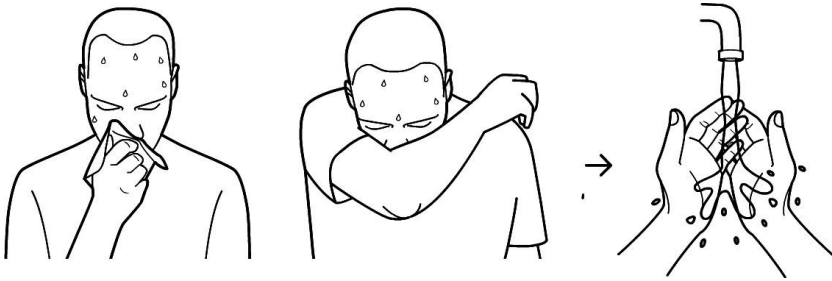

## Malaria

- **Malaria is a disease that is spread by infected mosquitoes.**
- **What do you see?**

The ill person may suffer from:

- fever (see page 104);
- coughing;
- headache;
- tiredness;
- painful muscles;
- abdominal pain;
- loss of appetite;
- dizziness;
- nausea.

- **What should you do?**

Give first aid for fever (see page 110).

- **When should you seek medical help?**

- Every person with malaria needs medical attention!
- A person living in malarial area who complains of severe headaches needs to be taken to a medical facility immediately, as cerebral malaria can be very dangerous and life-threatening.

- **Prevention**

- Always sleep under a bed net, preferably an insecticide-treated bed net. This is especially important for pregnant women and children below the age of 5. Use it correctly.

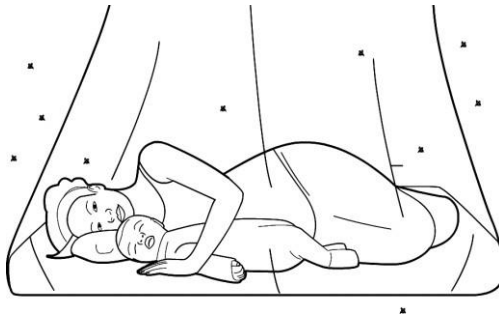

- Avoid or drain stagnant water in unused ditches and water holes or places, because mosquitos need water to breed. Maintain a clean environment around your home. Dispose waste that can hold water.
- Wear long-sleeved clothes and cover your feet, as mosquitos normally bite closer to the ground.
- Stay inside the house after sunset, because the mosquito that causes malaria is most active between sunset and sunrise.
- If you keep cattle, keep them outside the house, as animals inside the house increase the risk of getting malaria.

## 4.3 Fits



During a fit, the ill person suddenly starts to shake uncontrollably. It is different to normal shivering and trembling. It may manifest in all limbs or in just a single limb.

Fits may be caused by:

- epilepsy;
- a high fever (Febrile fits, see page 112);
- malaria (see page 108);
- brain injury;
- alcoholism;
- drugs;
- heart problems.



### What do you see?

The ill person may display the following signs:

- suddenly shaking uncontrollably;
- urinating or defecating without control;
- loss of consciousness;
- discolouration of the nails and lips;
- eyes turning away;
- experiencing strange sensations before the actual fit occurs:
  - seeing flashes of light;
  - hearing a murmur;
  - tasting something funny in the mouth.

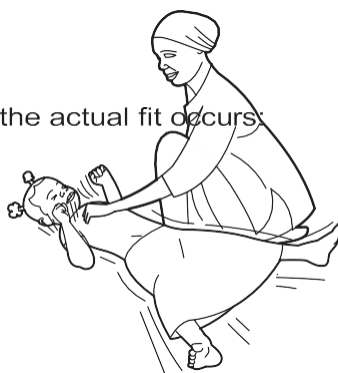



## What should you do?

- Remove objects that could hurt the person or move him to a safe place.
- If possible, put something soft under his head if he is lying on the ground.



- Make sure he can breathe freely by loosening tight clothing around the neck.
- When the fit stops, put him into the recovery position (see page 25). This will keep his breathing passage open.

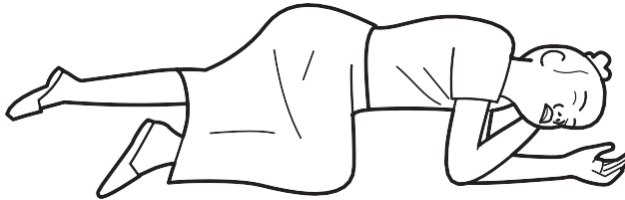

- Stay and talk calmly with him until he feels better.
- If the fit was caused by a high fever, give first aid for



- Do not try to hold the ill person down or put anything in his mouth:
- The person cannot swallow his own tongue during the fit;
- He might bite his own tongue but this normally heals in a few days;
- An object or a hand placed in the mouth of someone having a fit is dangerous for the ill person and yourself.

## When should you seek medical help?



A fit can be a sign of a serious illness. Any person having a fit needs medical attention. Medical attention is especially important if:

- it is the person's first fit;
- the fit lasts longer than 5 minutes;
- there is more than one fit and the ill person does not wake up between the fits;
- there is a high fever;
- the ill person has hurt himself;
- the ill person is under the influence of alcohol or drugs (talk kindly to him without making judgments).

Young children between the ages of 1 and 4 can often develop **febrile fits** as a result of high temperature caused by an infectious disease, or they can suffer from epileptic fits. A child having a fit should be examined by a doctor or taken to a medical center.



## Prevention

- If fits occur due to high fever, take measures to control the fever (see page 104).
- People known to have epilepsy attacks should avoid flickering lights and video games.

## 4.4 Diarrhoea



Diarrhoea is defined as the passage of three or more loose or liquid stools per day (or more frequent passage than is normal for the individual). Frequent passing of formed stools is not diarrhea, nor is the passage of loose 'pasty' stools by breast-fed babies.

Diarrhoea is usually caused by an infection. A person can catch this infection by:

- not washing his hands;
- touching stools;
- eating unsafe food, such as fish that was caught in polluted waters;
- drinking bad water;
- preparing food with bad water;
- food that has not been kept cold or has gone bad.

Diarrhoea causes dehydration, as too much water and nutrition leave the body. If an ill person does not receive help, he can die. Babies and children are most at risk.



## What do you see?

The ill person may:

- pass watery, thin stools;
- experience a frequent urge to pass stools. He sometimes has trouble keeping it under control;
- have cramps and may have to vomit;
- have a fever and sweat (see page 104);
- feel weak and ill;
- have a swollen abdomen.



## What should you do?

- Wash your hands before giving first aid. Use soap, or alternatively, ash.
- Prevent dehydration:
  - At the first sign of diarrhoea, give the ill person plenty to drink. Avoid the use of too much milk products. If available, soy milk can be used as an alternative.

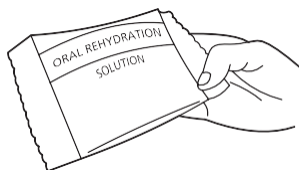

If not available, you can also prepare a rehydration drink yourself:

- Mix 2 fistfuls of maize flour (60 g) with 1 liter of water.
- Add 2 pinches of salt and mix well.

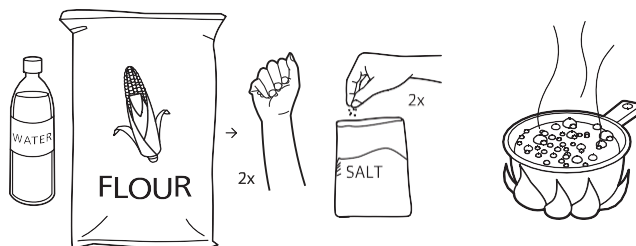

- Each time an ill person passes diarrhoea, he must drink to replace what he has lost:
  - Children under 2 years old:  
between a quarter and half a large cup of fluid (50-100 ml).
  - Children from 2 to 10 years old:  
between half and a full large cup (100-200 ml).
  - Older children and adults:  
at least 1 large cup (200 ml).



- If the ill person vomits, wait for 5-10 minutes before you give another drink. Then use a spoon to give the drink more slowly.
- Children should continue normal feeds:
  - Breast-fed babies:  
Continue to breast-feed but more frequently than usual.
  - Bottle-fed babies:  
Continue with normal feeds and give extra rehydration drinks.
  - Older children and adults:  
Eat as soon as they feel like it.
  - Wash your hands after giving first aid. Use soap, or alternatively, ash.
- If available, try to obtain zinc tablets or use zinc-fortified ORS instead of standard ORS.
- If the person also has a fever, give first aid for fever (see page 110).



## When should you seek medical help?

Seek medical help if the person becomes more ill or if you see any of these signs:

- very bad diarrhoea, blood in the diarrhoea;
- severe sleepiness, difficulty in waking up, confusion;
- vomiting;
- the ill person urinates less and the colour of the urine darkens, has sunken eyes, cries without tears, has a dry mouth;
- the ill person is not drinking;
- fits;
- breathing seems abnormal;
- diarrhoea is not improving after 2 days;
- fever.



## Prevention

- Wash your hands:
  - before preparing food;
  - after touching raw meat;
  - before eating;
  - before and after taking care of a sick person;
  - after using the toilet or latrine;
  - after changing a baby or after handling children's faeces.
- Use soap, or alternatively, ash.

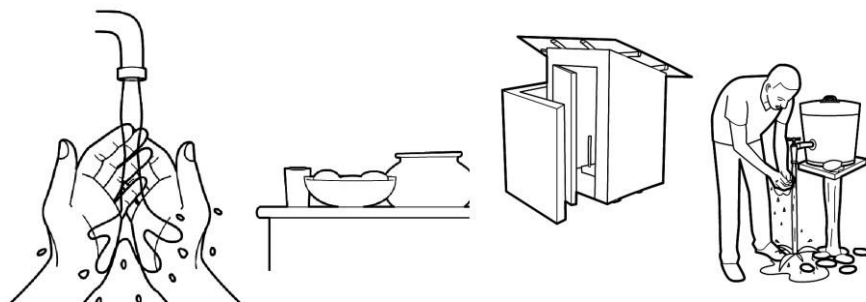

- Always throw away stools in the toilet or latrine. Also throw away the water used for washing children after defecation. Keep toilet areas away from water sources or water storage places.
- Always wash utensils that have been in contact with raw meat.
- Ensure that your food is completely cooked, especially when you prepare meat or eggs.



- Store food (including leftovers) carefully: cover it and keep it in a cool, clean and dry place; preferably in a fridge. Avoid food that looks spoiled or smells bad.
- Eating fruits and vegetables regularly reduces the risk of diarrhoea. Peel or wash raw fruit or vegetables with clean drinking water before eating. Do not eat raw fruit or vegetables that have been partially eaten by animals, because they can transmit diseases.
- Always clean cooking and eating materials immediately after eating and let them dry on a rack. Keep your household clean at all times.
- Use fresh, and not stored water, for the preparation of baby food or food for young children.

If no fresh water is available, use water stored in clean pots with a narrow mouth and lid at the top or a clean jerry can for storage of water. Jerry cans that contained petrol, paraffin or a chemical should not be used. Always close the lid after filling the water storage container.

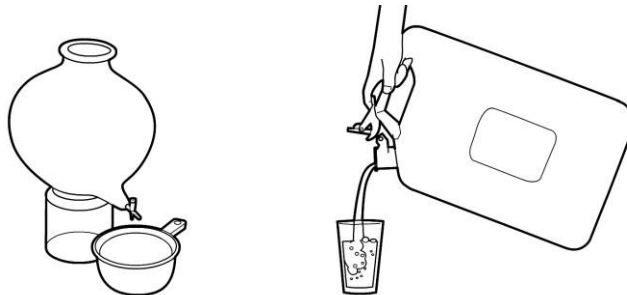

- Avoid eating food if you are not sure whether it has been safely prepared.
- Always drink clean water from a clean glass or container and use clean water to prepare food.
  - Use water from a protected source, like a:
    - piped supply;
    - borehole;
    - protected well or spring;
    - rain water collection.
  - Be aware that this can still be unsafe. Do not use water from shallow wells or other open sources that are open to contamination by animals, humans or waste.
  - Always disinfect water using one of the following methods:
    - Boiling: the water should bubble for at least 1 minute;



- Ceramic and biosand filtration;
- Using a product like chlorine or a flocculant/disinfectant powder;
- Solar disinfection.

## Cholera



- Cholera is a severe intestinal infection that is caused by consumption of food or drinking water that contains the bacteria. It results from poor sanitation and dirty drinking water. Regions where basic infrastructures are disrupted and water and sanitation provisions have been destroyed, are particularly vulnerable for cholera outbreaks.

- **What do you see?**

Cholera is characterized in its most severe form by a sudden onset of acute watery diarrhoea that can lead to death by severe dehydration.

- **What should you do?**

Give first aid for diarrhoea (see page 113).

- **When should you seek medical help?**

- Under normal circumstances, seek help as you would do for a person with diarrhoea (page 119);
- In an area where there is a cholera epidemic, you should immediately seek help if a patient develops acute watery diarrhoea.

## 4.5 Rash



Many medical conditions present with a rash, which can range from mild and harmless to serious. **Measles** is a highly contagious viral disease, which affects mostly children. It is transmitted via droplets from the nose, mouth or throat of infected persons.



### What do you see?

- Initial symptoms, which usually appear 10 to 12 days after infection, include:
  - High fever;
  - Runny nose;
  - Cough;
  - Red and watery eyes;
  - Tiny white spots on the inside of the mouth.
- Several days later, a rash develops, starting on the face and upper neck and gradually spreading downwards. A rash can be difficult to see on dark skin: look for roughness on the skin.



## What should you do?

- Wash your hands before giving first aid. Use soap, or alternatively, ash.



- Give first aid for fever (see page 104).
- In case of irritated eyes:
  - Put the child to bed in a semi-dark room;
  - Dip lukewarm water onto the eyes of the child.
- Wash your hands after giving first aid. Use soap, or



## When should you seek medical help?

Measles can cause death and other infections. Sometimes, it can lead to complications, such as:

- malnutrition;
- blindness;
- deafness;
- lung disease;
- brain damage.



## Prevention

- Contact a health worker to ask about the measles vaccination. Like people who have already had measles, vaccinated children are extremely unlikely to get measles.
- Keep children with measles away from other children for at least 5 days after the rash has disappeared, to prevent them from getting ill too.

Seek medical help if you see that the child:

- is not drinking;
- is very sleepy and difficult to wake up;
- vomits a lot, has diarrhoea or shows signs of dehydration;
- is breathing fast;
- has fits;
- cannot bear light;
- has an earache or has pus coming from the ear;
- has an eye infection;
- has sores or open lesions in the mouth;
- displays spontaneous bleeding or small spots of blood leakage in the skin.

If the ill person must travel for help, keep giving him sips of water or liquid on the way there.

## 5. Content of first aid kits

### 5.1. SMALL FIRST AID BOX

- 1 tube silver sulfadiazine ointment 15 g
- 10 band aid strips
- 1 roller bandage 5x5 cm
- 1 package absorbent sterilized cotton 15 g
- 1 scissor 7cm (sharp/blunt edge)
- 10 tablets paracetamol
- 1 plastic mouth-to-mouth resuscitator
- 1 triangular bandage (90 cm)
- 10 safety pins
- 1 adhesive plaster/tape
- 3-4 ice cream spoons to be used as splints of finger
- 2 ORS sachets

### 5.2. EDIUM FIRST AID BOX

- 10 sterilized finger dressings
- 10 sterilized foot and hand dressings
- 10 sterilized large dressings
- 1 sterilized extra-large dressings
- 2 sterilized first aid field dressings
- 2 sterilized shell dressings
- 4 sterilized small burn dressings
- 2 sterilized large burn dressings
- 50 adhesive dressing strips
- 4 roller bandages 5 cm (5 m)
- 2 roller bandages 7.5 cm (5 m)
- 6 triangular bandages (90 cm)
- 1 package gauze 7.5 cm
- 4 package sterilized absorbent cotton 25 g
- 6 sterilized eye pads (st John pattern)

1 spool adhesive plaster 2.5 cm (5 m)

1 tube silver sulfadiazine skin ointment 15 g

- 1 bottle savlon, detol or catavelon 112 ml
- 2 surgical scissors 12.5 cm (sharp/blunt edge)
- 1 mouth-to-mouth resuscitator
- 3 inflatable arm splints
- 3 inflatable leg splints
- 1 torch (2 battery cells)
- 10 safety pins
- 3-4 ice cream spoons to be used as splints of finger
- 2 ORS sachets
- 1 writing pad and pen
- 1 record card in plastic cover
- 1 first aid leaflet form

### **5.3. LARGE FIRST AID BOX**

- 18 sterilized finger dressings
- 24 sterilized foot and hand dressings
- 20 sterilized large dressings
- 2 sterilized extra-large dressing
- 4 sterilized first aid field dressings
- 6 sterilized shell dressings
- 6 sterilized small burn dressings
- 4 sterilized large burn dressings
- 100 adhesive dressing strips
- 6 roller bandages 5 cm (5 m)
- 6 roller bandages 7.5 cm (5 m)
- 12 triangular bandages (90 cm)
- 1 package gauze 7.5 cm
- 8 package sterilized absorbent cotton 25 g
- 6 sterilized eye pads (st John pattern)
- 2 spool adhesive plaster 2.5 cm (5 m)
- 1 tube sliver sulfadiazine skin ointment 15 g
- 1 bottle savlon, detol or catavelon 112 ml
- 2 surgical scissors 12.5 cm (sharp/blunt edge)

- 1 mouth-to-mouth resuscitator
- 3 inflatable arm splints
- 3 inflatable leg splints
- 3-4 ice cream spoons to be used as splints of finger
- 2 ORS sachets
- 2 torch (2 battery cells)
- 10 safety pins
- 1 writing pad and pen
- 1 record card in plastic cover
- 1 first aid leaflet form







